



FAMILY - RESPECT - SPORTSMANSHIP



**RULE BOOK**



## TABLE OF CONTENTS

Membership	5
Non-Pro Membership Conditions	6
Non-Pro Relinquishment	7
Apprentice Program	7
Green Rider Level 1 & 2	8
Leases	8
Horse Competition License	8
Horse Age for Showing	10
Class Eligibility	10
Sanctioned Classes	11
Warm Up/Schooling Policy	11
Show Attire	12
General Show Conditions	12
Added Money	14
Event Approval	15
Event Classification	15
Show Results	16
Show Manager	16
Show Secretary	17
Show Representative	18
End of Year Awards	18
Worksheet for RA Paybacks	19
Youth Rules and Show Conditions	20
Rules for Judges	23
Para Reining	35
General Judging and Scoring Guidelines	36
Penalty Application	38
Equipment Check	39
Penalty No Score	40
Penalty Score Zero	42
Five Point Penalties	44
Two Point Penalties	45
Lead Penalties	46
Jog Penalties	47
Simple Lead Change Penalties	47
Spin Penalties	48
Wall Penalty	49
Centre Penalty	49
Reviews	49
Descriptions of Manoeuvres	50
Scoring	52
Conduct	55
Freestyle Reining – General Rules	57
Reining Patterns	59



## **WELCOME TO REINING AUSTRALIA**

Reining Australia Inc. ("RA") is a non-profit organization dedicated to the promotion of the reining horse. RA was formed in 1988 with the purpose of growing and supporting our great sport of reining.

RA, led by successive boards, is guided by a carefully worded constitution. From this document and member input, the elected board draws its direction with a focus on our members and their eligibility to show. Most notably, the Board is responsible for the continued development of the judges' program and the scoring system it relies on.

A feature of the reining year is the RA's Australian National Reining Championships featuring the Gold Buckle Futurity and Affiliate Championships and the significant prize money on offer.

RA proudly represents all our members and affiliates, by providing a competitive arena where we hold true the values family, respect, and sportsmanship. Check out our website at [www.reiningaustralia.com](http://www.reiningaustralia.com).

## **Membership**

All persons participating in an event (training day, clinic, beginner show, ribbon show, Jackpot and RA Approved Shows) run by an RA affiliate must hold a Reining Australia membership in one or more of the following categories:

- Full member,
- Green Rider,
- Youth,
- Associate,
- or a member of their local affiliate.

To give prospective members the opportunity to attend an event, there is provision for them to pay the affiliate holding the event a one-off event membership fee, and sign a waiver/release form. The recommended fee is \$25 (AU).

Reining Australia Full Membership is the same for Professional and Non-Pros.

The following Programs are available to RA members:

- Green Rider Program
- Australian National Reining Championships featuring Gold Buckle Futurity and RA Derby
- Gold Buckle Futurity Program
- Australian Reining Breeders Classic
- Reining Australia Earnings and Eligibilities
- Reining Australia End of Year High Point Awards and Top Ten Recognition
- Mare of the Year
- Hall of Fame, Legends
- Reining Australia Affiliate Championship

Membership Fees are available at [www.reiningaustralia.com](http://www.reiningaustralia.com).

- Full membership (general/Non-Pro)
- Reining Australia professional
- Green Rider program
- Reining Australia Youth membership
- Associate membership

## **Non-Pro Membership Conditions**

All Non-Pros must have a Non-Pro Declaration on file.

A Non-Pro shall be defined as a person who:

- (1) At the time of the member's Non-Pro application and Declaration, has not won more than \$100,000 in Open reining competition.
- (2) In the three years preceding the date of application has not received remuneration for the following activities:
  - (i) Training or showing astride in any equine discipline;
  - (ii) Giving instruction on the showing or Training of a performance horse; or
  - (iii) Sponsorships or endorsements unless approved by the Board.
- (3) Remuneration is defined as the receipt of:
  - (i) Money, pay, or financial gain for work completed; or
  - (ii) Goods, services, or discounts in return for work completed.
  - (iii) This does not include prize money.
- (4) Training is the mounted preparation of a horse with the intent to improve the horse's performance in any equine discipline.
- (5) Giving instruction on the showing or training of a performance horse means providing coaching or lessons with the intent to improve the rider's ability to show or train a performance horse.
  - (i) RA does not consider occasional and irregular encouragement or collaboration among Non-Pros to be "giving instruction" as long as this is not done for remuneration. Such sportsmanship among Non-Pros is encouraged by RA.
- (6) Performance horse includes horses that engage in the western stock sports, including but not limited to, reining, reined cow horse, cutting, roping, ranch riding, ranch versatility, etc.
- (7) RA does not consider an RA Professional's spouse or family members to be ineligible for Non-Pro status unless they themselves receive remuneration for the Prohibited Activities. Those individuals can show as Non-Pros as long as they meet the requirements.
- (8) A person who is ineligible to obtain Non-Pro status may become eligible by meeting all Non-Pro requirements for a period of three years. During the ineligible time period, the member may only show in Open competition.

- (9) Ownership: A horse shown in Non-Pro competition must be solely and completely owned by one of the following:
- (1) The Non-Pro
  - (2) Member(s) of the Non-Pro's immediate family
  - (3) A corporation, partnership, or other business entity provided that the Non-Pro and/or members of his/her immediate family are the sole owners of that business entity and the ownership of that business entity does not change to include non-immediate family members or entities.
  - (4) A Non-Pro rider may compete on a leased horse, see conditions below.
- (10) Immediate family is defined as: spouse, de facto partner, parent, spouse's parent, partner's parent, step-parent, legal guardian, child, step-child, sibling, sibling's spouse, sibling's partner, half-sibling, step-sibling, aunt, uncle, grandmother, and grandfather and in-laws of the same relation as stated above, or a legal union as defined by the Commonwealth of Australia.
- (11) Entry fees and/or expenses paid by anyone other than the Non-Pro, his/her immediate family, or a family-owned business entity as outlined above, shall be considered remuneration and could jeopardize Non-Pro status.
- (12) Any transaction relating to the sale or transfer of a horse to a Non-Pro other than by immediate family members must be at fair market value. The Non-Pro is responsible for documenting said transaction in a satisfactory fashion in the event of any protest. If a Non-Pro and/or his/her immediate family member sells a horse and then buys it back, that horse cannot be shown in Non-Pro classes for 180 days from the date of the original sale.

### **Non-Pro Relinquishment**

A Non-Pro who gives up his/her Non-Pro status to become a RA Professional member must complete and submit the Non-Pro relinquishment form within 30 days of becoming a RA Professional or a professional trainer. Non-Pro earnings in any category/class will not be utilized to determine current eligibility, with the exception of Aged Events and Rookie Professional class.

### **Apprentice Program**

The Non-Pro must complete an Apprentice Program application. Application forms and conditions can be found on the RA Website. Applicants must be at least 18 years of age. A Non-Pro may participate in the Apprentice Program only once.

## **Green Rider Level 1 & 2**

The Green Rider program is an introduction to reining and encourages riders to compete without the restrictions of sanctioned classes. A competitor must be a Non-Pro to be eligible for the program. All competitors must register on-line. All applications and conditions can be found on the RA website. Some of the conditions are:

- Entry fees are to be determined by show management.
- Show management cannot charge a judge's fee.
- Must use patterns 1–15. Simple lead changes are allowed, and the rider may use one (1) or two (2) hands on the reins or change from one-handed to two-handed throughout the performance.
- Any legal headgear and equipment are allowed.

## **Leases**

A leased horse may be shown in Non-Pro competition under the following guidelines:

- (1) Prior to showing, the lessee (Non-Pro) showing the leased horse, must have a lease on file and all fees paid prior to competing.
- (2) The lease must be to an individual only. There are no restrictions to the number of times the lease can be renewed. All leases end the 31 December.
- (3) During the term of the lease, the lessee, and his/her immediate family may show the leased horse in all classes, excluding Aged events.
- (4) A Professionals member may show the leased horse in open competition including Aged Events.
- (5) Only one lease at a time per horse per year will be recognized.
- (6) The lessor may not show the horse during the term of the lease.
- (7) The lessor must be a current RA member in good standing. An Associate membership is acceptable.

## **Horse Competition License**

Competitors competing in sanctioned classes must have a horse competition license. NRHA competition licenses issued by NRHA prior to on 31 December 2021 will be accepted for showing horses at RA approved Shows. Horses licensed on or after 1 January 2022 must hold a Reining Australia competition license. An NRHA license will not be accepted.



Competitors in non-sanctioned events such as Beginner, Ladies, Gents, Green Rider, etc., do not need a competition license and may use a horse without the restrictions of ownership. Riders in Rookie Level 1 and 2 classes may use a horse without the restrictions of ownership.

- (1) The RA competition license is a permanent identification record assigned to each horse. All horses competing in RA approved competition are required to have a competition license.
- (2) A photocopy of the horse's registration papers must accompany the application. For unregistered horses, photographs of the horse's front, back, left, and right sides must accompany the application and proof of ownership.
- (3) It is the purchaser's responsibility to obtain a horse's competition license from the previous owner, and to submit all transfer paperwork and fees prior to showing the horse. The competition license, or the license transfer, is effective on the date it is received in the RA office.
- (4) The competition license must be shown to the show secretary at RA approved events. All competition license applications and transfers of ownership must be completed prior to competing.
- (5) Competition licenses that have been lost for any reason can be replaced by applying to the RA Office and submitting the appropriate fee.
- (6) When a horse is gelded, the owner must report it to RA immediately and have change noted on the competition license .

There are additional fees for replacement licenses and ownership transfers.

RA Competition Licenses, Leases and Non-Pro declarations can be obtained on the RA website.

RA Competition License emailed	\$33
Transfer of ownership	\$33
Replacement Competition License	\$11
RA CL Posted Hardcopy	\$44
RA Lease	\$55
Non-Pro Declaration	\$33

## **Horse Age for Showing**

No horse may be shown before it is 3 years old (as of 1st of August) in Reining events, and that includes showing in training classes. It is acceptable for a 2-year-old to be ridden at clinics. This rule applies to all RA approved events.

## **Class Eligibility**

Class Eligibility for the current show year for horses and riders can be found on the RA website. The Reining Australia Ineligibility List will run from 1st July of each year. Earnings are recorded each show year from all Reining Shows.

The reasons for class eligibilities are to:

- Create a fair and equitable playing field.
- Encourage and inspire progression through the sport.
- Reflect the ability of horse and rider competing within each level.
- Cater for the majority within each level.
- Strike a balance between good numbers in classes and ensuring the same horses and/or riders do not dominate levels by being eligible for too long.
- Encourage new riders to our industry so that our sport continues to grow.

## **RA Capping for ineligibility**

### *Ancillary Classes*

Rookie Level 1	Lifetime earnings \$200
Rookie Level 2	Lifetime earnings \$500
Rookie Professional	Lifetime earnings \$5000
Limited Non-Pro	Lifetime earnings \$3000
Limited Open	Lifetime earnings \$5000
Intermediate Non-Pro	\$4500 over previous three years
Intermediate Open	\$9000 over previous three years
Novice Horse Level 1	Lifetime earnings \$2000
Novice Horse Level 2	Lifetime earnings \$5000

### *Aged Events*

Limited Open Aged Event	\$9000 in Category 2 over previous three years
Limited Non-Pro Aged Event	\$3000 in Category 2 over previous three years
Intermediate Open Aged Event	\$18000 in Category 2 over previous three years
Intermediate Non-Pro Aged Event	\$6000 in Category 2 over previous three years

## **Sanctioned Classes**

### *Ancillary classes*

Open, Non-Pro, Intermediate Open, Intermediate Non-Pro, Limited Open, Limited Non-Pro, Rookie Professional, Rookie Level 1, Rookie Level 2, Prime Time Non-Pro, Novice Horse Open Level 1, Novice Horse Open Level 2, Novice Horse Non-Pro Level 1, Novice Horse Non-Pro Level 2, Youth 13 Years and Under, Youth 14 to 18 Years.

### *Aged Events*

Snaffle Bit/Hackamore: 3-year-old (ridden two-handed)

Futurity: 4-year-old

Maturity: 5-year-old

Derby: 5, 6, 7 and 8 years

## **Warm Up/Schooling Policy**

### *Arena/Warm-up arena plan*

In support of the RA Animal Welfare Policy and to ensure a safe and effective schooling environment, Reining Australia has provided a written plan for safe schooling opportunities. The plan includes the maximum number of horses (16) that are to be in the arena at any one time.

### *Length of time riding*

It is mandated at RA events that horses be not ridden to excess. The approximate guideline is not more than two hours of riding at a time. After riding, the horse must be rested with access to feed and water.

### *Arena rules*

1. Number of horses in the arena at any given time is limited to 16.
2. Circles on the lower end of the arena, or closest to in gate, are to the left.
3. Circles on the top end or furthest from in gate, are to the right.
4. Do not stop, school, or spin, in the center of the arena as you will be in the traffic of other riders.
5. Run large fast circles on the outer path; if trotting or exercise loping, ride slightly further in on a smaller circle to stay out of the path of those running large fast circles.
6. Spin or air your horse up in the center of either circle.
7. First half hour circles (Green Lights) second half hour run downs (Red Lights)
8. Do not ride or gather in groups as it further congests the arena and makes it hard for others to ride around you.
9. Do not continue to ride if your horse is in an "unfit condition" such as out of air, overly tired or lame.
10. No lunging and no un-saddling horse in the arena.

*Tractor etiquette. All arenas will follow these guidelines:*

- All horses will stop forward movement.
- All horses will move to the side of the arena opposite from the tractor and drag.
- All riders will watch for and obey tractor driver's direction.
- Riding will continue ONLY after tractor and drag have exited the arena.

These guidelines apply regardless of the number of horses in the arena. Any violation of these guidelines may be viewed as unsportsmanlike conduct leading to disciplinary action.

### **Show Attire**

When you enter the arena to show, you must be wearing a western hat or safety hat, long-sleeved western shirt with sleeves buttoned down and boots and your horse must have a western saddle and western bridle. Failure to have correct attire upon entering the arena will result in a SCORE 0. Losing your hat within a run does not attract a penalty.

#### **Presentations**

All horses should return to the pen for presentation and all competitors, and handlers entering the arena for presentation must be wearing a hat, long-sleeved shirt and covered footwear. Competitors must be astride. Caps and short-sleeved shirts are acceptable only during Paid Warmups and Open Pen.

### **General Show Conditions**

- (1) All entry forms must accurately and truthfully identify horses, owners, and riders (based on records in RA database), when the information is asked for from the exhibitor. Inaccurate information can affect official RA earnings records.
- (2) All exhibitors and owners/co-owners must be current RA members in good standing.
- (3) Class working order is determined by a draw. All horses in a class must run as drawn.
- (4) The class draw must be available to exhibitors at least one hour prior to the first horse entering the arena. When class entries close the day before the class is to be held, the draw must be posted by 9:00 pm on the closing date.
- (5) If an entry is made after the draw is posted, it is the decision of the show management as to whether that entry runs first or last. The policy must be consistent for all late entries in that class except when exhibitors are showing multiple horses.

- (6) Exhibitors that enter and scratch a class for any reason after the draw has been posted will be liable for any and all fees incurred in connection to entering that class.
- (7) All horses must display the correct exhibitor number. Failure to display the number, or displaying the wrong exhibitor number, may incur a fine of (\$25) this will be at the discretion of Show Management.
- (8) If an entrant misses his/her turn as determined by the draw, he/she will be disqualified from that go-round (except in unusual and unavoidable circumstances). Class judges will determine each case on its own merit.
- (9) Rider substitutions will not be permitted except when the show management and RA Representative mutually agree, such as when an exhibitor becomes injured or other extenuating circumstances prevail.
- (10) If a rider rides more than one horse, there should be a spread of at least eight (8) horses between his/her runs. When this is not possible due to a limited number of entries, the spread should be the maximum possible. A horse may be entered only once per class. In Para-Reining, a rider may ride up to but no more than three horses per class. A horse may be shown a maximum of two (2) times in the same class under different Para-Reining riders.
- (11) All horses must be ridden astride.
- (12) All judges' decisions are final.
- (13) It is mandatory for all riders to use appropriate western tack and western attire while showing; this would include a long-sleeved shirt, western hat or safety helmet, boots, western saddle, and western bridle. (Freestyle reining is exempt from these conditions.) Failure to use appropriate attire will result in a SCORE 0. The use of an ASTM/SEI certified helmet is mandatory in all Para-Reining classes and/or any time a Para-Reining rider is mounted.
- (14) The Affiliate, show committee, and all participants, spectators, and others acknowledge that because these rules have been established on the basis of experience and fairness to all who are interested in the betterment of reining horse competition, RA assumes no liability for any injuries, damages, or claims from any Affiliate, show committee, participant, or spectator, arising out of performance conducted under the RA General Rules and Regulations.

- (15) Any person or entity in violation of RA rules may be subject to, but not limited to, fines, forfeitures, exclusion from Top Ten End of Year Awards, probation, and/or disciplinary procedures.
- (16) By entering an RA approved event, horse owners and exhibitors are granting the RA and the event's organizers permission to use the images taken of them by the official event photographer and the official videographer for any and all educational, promotional, and review purposes.
- (17) It is recommended that all Affiliates offer a full program of sanctioned classes as listed above.

### **Added Money**

#### *Maximum added money*

Limited Open: \$500, Entry Fee 10% of added money or \$50, jackpot

Rookie Professional: \$500, Entry Fee 10% of added money or \$50, jackpot

Limited Non-Pro: \$500, Entry Fee 10% of added money or \$50, jackpot

Rookie Level 2: \$200, Entry Fee \$20

Rookie Level 1: Jackpot only, Entry Fee \$20

Youth Classes: It is recommended that no prize money be offered for Youth classes.

- (a) The following classes may not be jackpotted: Open, Intermediate Open, Limited Open, and Non-Pro; other classes may be approved as a jackpot.
- (b) The Open class must offer the equivalent or more added money than any other class at an event.
- (c) When Intermediate classes are offered, the added money may not exceed the added money offered in either the Open or Non-Pro classes.
- (d) Prime Time Non-Pro added money may not exceed the added money in the Intermediate Non-Pro class.
- (e) Rookie Level 1 and Level 2 entry fees may not exceed that of the Limited Non-Pro.
- (f) Rookie Level 1 entry fees may not exceed that of the Rookie Level 2.
- (g) Judge's fees may not exceed the entry fee.
- (h) Show management must retain between thirty (30%) and fifty (50%) of the entry fees, all classes within the show must have the same retainage. Exception Aged Events.

## **Event Approval**

RA may approve events that meet the approval criteria outlined in the RA Rule Book. For RA approval, organizers must staff the event with a show manager, secretary, and show representative who are current RA General, Non-Pro, or Professional members in good standing. Show managers and officials must also meet certification requirements and follow all guidelines as outlined in this Rule Book. It is recommended that judges be selected from the official RA Judges list, wherever possible.

- (1) An RA show is a group of classes which may also be referred to as a slate of classes.
- (2) Official RA event approval forms must be submitted to the RA office 30 days prior to the start date of the Show.

Any changes made to information on a submitted event approval form must be done in a timely manner.

Any changes to added money, entry fees, or retainage fees for classes that count toward Top Ten standings must be submitted 30 days prior to the event's entry closing date.

- (3) Show approvals are awarded on a first come basis except in cases of established events.
- (4) The Board may deny approval of events scheduled during the same week as the Australian National Reining Championships.
- (5) It is recommended that at least two (2) chair judges be used in all RA approved classes with \$5,000–\$9,999 in added money. At least three (3) chair judges are recommended, but a minimum of two (2) chair judges are required, for all RA approved classes with \$10,000–\$50,000 in added money. Five (5) chair judges are recommended, but a minimum of three (3) chair judges are required, for all RA approved classes with over \$50,000 in added money.

## **Event Classification**

### *RA Ribbon Show*

It is recommended that all Ribbon Shows have a Show Secretary and a Show Manager/Show Representative. Where possible they should be two separate individuals. It is recommended that the Show Secretary or Show Manager be certified by RA.

### *RA Jackpot Show*

As Above

### *National, State or Major Shows (added prize money)*

Must have a Show Secretary, Show Manager and a Show Representative who should be three separate individuals.

It is mandatory that judges be selected from the official RA Judges list. A videographer for all classes is strongly recommended. Judges are not required to judge more than 12 hours per day, actual judging, not including breaks.

### **Show Results**

- Show results are to be received in the RA office within ten (10) business days following the completion of the RA event.
- For National, State, or major shows, a show representative report also must be lodged.
- Show results must record all riders and horses shown, including scratches, zeroes, and no scores in the proper placing.
- Show results must include membership numbers for all riders and owners/co-owners, and competition license numbers for every horse.
- Earnings must be paid to riders/owners within thirty (30) days of the event.
- Score sheets are to be kept for 12 months with the RA affiliate.

### **Show Manager**

Any reputable person who can furnish proof that he/she is capable through ability and experience may act in the capacity of show manager. RA approved Show manager must have a current RA membership.

The show manager shall:

- (i) Be the person in charge of all divisions of the show but may not serve at Secretary or Show Representative at any show he/she is managing.
- (ii) Have authority to enforce all rules pertaining to the show. He/she may excuse any horse or exhibitor from the show prior to during or after the judging.
- (iii) Be present on the show grounds for the duration of the show. If an emergency arises and the show manager is unable to fulfil his/her duties, an acting manager should be appointed. The acting show manager must remain at the show grounds for the duration of the show.
- (iv) Extend every effort to satisfy the comfort of horses, exhibitors, spectators, and officials and will be held responsible for maintaining clean and orderly conditions throughout the show. The show manager (along with



the Representative) is responsible for ensuring humane treatment of horses by policing stalling areas, practice pens, and other areas at various times throughout the show.

- (v) Receive written or verbal complaints from exhibitor's trainers, show participants, owners and other RA members related to cruel, abusive, or inhumane treatment of horses on show grounds, or any other complaints, incidents, or rule violations. The show manager shall forward such complaints to RA. Complaints Form can be found on the RA Website Forms and Documents.
- (vi) Immediately investigate inhumane treatment incidents and report them to RA. Show managers shall make every effort to enlist judges, stewards, or Professionals to help substantiate a horse welfare complaint. Whenever a show manager issues a verbal or written warning for the inhumane treatment of a horse, it is to be reported in writing to Reining Australia.

Show schedules should not run more than 12 consecutive hours, excluding all breaks.

It is the show manager's responsibility to ensure that classification requirements are met for the event and that proper documentation is kept in case of a protest. Failure to do so may result in a review and possible disciplinary action.

### **Show Secretary**

Any reputable person who can furnish proof that he/she is capable through ability or experience may act in the capacity of show secretary. He/she must have a current RA General, Non-Pro, or Professionals membership.

It is recommended that the show secretary complete a RA Show Secretary Course.

The show secretary shall:

- (i) Accurately maintain and record both entries and show results, and aid exhibitors in determining their eligibility.
- (ii) Keep a complete set of results and judges' score sheets on file for at least one year from the show date.
- (iii) Oversee any and all show-related fees, such as: entry fees, judges' fees, stable fees; office charges; and medications testing fees, (if applicable) membership and competition licensing fees collected on behalf of RA.

- (iv) Be responsible for checking entries to ensure that exhibitors and owners are current RA members, and that horse competition licenses reflect current ownership.
- (v) Be present on the grounds for the show's duration. If an emergency arises and the show secretary is unable to fulfill his/her duties, an acting secretary should be appointed. He/she must meet RA requirements.
- (vi) Be responsible for upholding all RA rules and regulations.
- (vii) Ensure that the classification requirements for the event are being met, and to keep proper documentation in case of a protest.

### **Show Representative**

The show representative represents contestants' interests to judges and show management. He/she will be required to submit a representative's report to RA not more than fifteen (15) days after the show.

The representative represents every contestant, and he/she is the sole liaison between a contestant and the show managers and judges. Contestants and owners should direct any and all concerns with respect to judging to the appointed representative and limit interactions with judges to polite exchanges.

At RA approved shows, a show representative must be an RA member in good standing. The Board recommends that the representative be either a current RA judge or a Professional trainer. Further, a show representative cannot be a member of show staff or a show official. A show representative will be knowledgeable of RA rules and the application thereof and will act in a manner fitting and proper for one afforded the honour of show representative. This is to remain a voluntary and uncompensated position. The show representative will clearly post his/her name and contact information for exhibitors. Should the representative leave the show grounds for any reason, he/she will appoint a qualified alternate representative (as outlined above).

The representative must report any horse abuse, or any actions detrimental to its members, such as: loud and profane language; drunkenness or being under the influence of intoxicants; use of prohibited devices; unsportsmanlike conduct toward judges, show management, or other exhibitors.

### **End of Year Awards**

The top ten End of Year Awards and Ineligibility List will run from 1st July of each year. All sanctioned classes are eligible.

## Worksheet for RA Paybacks

The entire amount of advertised added money will be paid according to the appropriate payback schedule.

Entry fee	X	Number of entries	=	Gross entry fees	(A)
Gross entry fees	(A)	X	=	Amt retained by show committee	(B)
Gross entry fees	(A)	-	(B)	=	Final net entry fees (C)
Final net entry fees	(C)	+	=	Purse for figuring paybacks	

### RA PAYBACK SCHEDULE A

Use this payback schedule for all RA classes EXCEPT \$2000 or more added classes

#### NUMBER OF HORSES ENTERED

	1	2-5	6-9	10-13	14-18	19-24	25-28	29-32	33-36	37-40	41-44	45-48	49-52	53-60	61+
# OF PLACES	1	2	3	4	5	6	7	8	9	10	11	12	13	14	15
1	100%	60%	45%	40%	34%	32%	28%	26%	25%	25%	25%	23%	23%	23%	23%
2		40	35	30	27	22	22	22	20	18	17	17	16	15	14
3			20	20	20	19	17	14	13	13	12	12	11	10.5	10.5
4				10	10	10	10	10	10	10	9.5	9	9	9	9
5					9	9	9	9	9	8.5	8	8	8	8	8
6						8	8	8	8	7	7	7	7	7	7
7							6	6	6	6	6	6	6	6	6
8								5	5	5	5	5	5	5	5
9									4	4	4	4	4	4	4
10										3.5	3.5	3.5	3.5	3.5	3.5
11											3	3	3	3	3
12												2.5	2.5	2.5	2.5
13													2	2	2
14														1.5	1.5
15															1
		100	100	100	100	100	100	100	100	100	100	100	100	100	100

### RA PAYBACK SCHEDULE B

Use this payback schedule for RA classes with \$2000 or more added

#### NUMBER OF HORSES ENTERED

	1	2-5	6-7	8-9	10-11	12-13	14-15	16-17	18-19	20-21	22-23	24-25	26-27	28-29	30+
# OF PLACES	1	2	3	4	5	6	7	8	9	10	11	12	13	14	15
1	100%	60%	45%	40%	34%	32%	28%	26%	25%	25%	25%	23%	23%	23%	23%
2		40	35	30	27	22	22	22	20	18	17	17	16	15	14
3			20	20	20	19	17	14	13	13	12	12	11	10.5	10.5
4				10	10	10	10	10	10	10	9.5	9	9	9	9
5					9	9	9	9	9	8.5	8	8	8	8	8
6						8	8	8	8	7	7	7	7	7	7
7							6	6	6	6	6	6	6	6	6
8								5	5	5	5	5	5	5	5
9									4	4	4	4	4	4	4
10										3.5	3.5	3.5	3.5	3.5	3.5
11											3	3	3	3	3
12												2.5	2.5	2.5	2.5
13													2	2	2
14														1.5	1.5
15															1
		100	100	100	100	100	100	100	100	100	100	100	100	100	100

## **Youth Rules and Show Conditions**

- (1) Any youth eighteen (18) years of age or younger as of January 1 may become a member of Reining Australia.
- (2) Youth membership entitles a youth to show in any RA class for which they are eligible. To show in an RA Non-Pro class, the youth must obtain an RA Youth Non-Pro card. Youth may not show in Rookie Professional.
- (3) All horses shown in the Youth 13 Years and Under and Youth 14 to 18 Years classes must be solely and completely owned by one of the following: (a) the youth, (b) a member of his or her immediate family [Refer to definition of immediate family on page 7], (c) a corporation, partnership or other business entity provided the youth and/or a member or members of his or her immediate family are the sole and only owners of that business entity and the ownership of that business entity does not change to include non-immediate family members or entities. The competition license will provide evidence of ownership.
- (4) Leases: A leased horse may be shown in Youth competition under the following guidelines:
  - (i) Prior to showing, the lessee (Youth) showing the leased horse, must submit a completed lease application and all fees prior to competing.
  - (ii) The lease must be to an individual only. There are no restrictions to the number of times the lease can be renewed. All leases end on the 31 December of the calendar year.
  - (iii) During the term of the lease, the lessee may show the leased horse in all classes, excluding Aged Events.
  - (iv) A Professional member may show the leased horse in Open competition.
  - (v) Only one lease at a time per horse per year will be recognized.
  - (vi) The lessor may not show the horse during the term of the lease. (See NOTE below for exceptions.)
  - (vii) The lessor must be a current RA member in good standing. An Associate membership is acceptable.
  - (viii) During the term of the lease, all points and/or monies earned will be credited to the lessee.

NOTE: RA Professionals may show a leased horse in any Open competition they are eligible for, even if they are the owner (lessor) of the leased horse. This includes Aged Events.

Lessors with Non-Pro, Youth, Youth Non-Pro or Associate memberships may show the leased horse in Green Rider and non-sanctioned events, and in Rookie Level 1 and 2. Additionally, lessors may show the leased horse in any Open competition for which they are eligible.

- (5) No stallions, monorchid or cryptorchid horses, regardless of age, will be permitted in any Youth classes. If the competition license indicates "stallion" for a horse that has been gelded, entry into an RA approved Youth class requires that a gelding statement form be filed with the show results and the original competition license be submitted to the RA office within 30 days of the show date for modification. Failure to comply will result in the forfeiture of earnings and awards.
- (6) Any youth rider participating in the Rookie Level 1 or 2 class for which he/she is not eligible will not be fined for the first offense. They must forfeit earnings to RA. Receipt of notice a second offense may result in a fine. After receipt of a second notice, any further offense may result in a fine.
- (7) There will be no judges' fee charge in any Youth classes.
- (8) Entry fee for Youth classes may not exceed \$10.
- (9) It is recommended that Youth classes are awarded points only, no prize money.
- (10) Youth Divisions
  - Short Stirrup (10 years and under)
  - Youth 13 and Under
  - Youth 14 to 18 Years
- (11) All Youth 13 years and Under are required to wear helmets when riding at any Reining Australia show or clinics. All helmets must comply with the current standards. These should be checked every year by parents or guardians. (Please refer to the Reining Australia website.)
- (12) Youth are not permitted to handle, ride or exhibit colts or stallions at any Reining Australia events. An application for exception to this rule may be made with the following criteria (Refer Youth Stallion Policy):
  - (i) Youth must be aged 16 years, or older.
  - (ii) A comprehensive Safety Risk Assessment must be provided with the written application.
  - (iii) All written applications must be made by an adult; the adult must be a current member of RA.
  - (iv) An administrative fee of \$25 must be paid with the application.

## Youth point scale

### Number of horses/number of places

	1	2	3	4	5	6	7	8	9	10+
1	1	2	3	4	5	6	7	8	9	10
2		1	2	3	4	5	6	7	8	9
3			1	2	3	4	5	6	7	8
4				1	2	3	4	5	6	7
5					1	2	3	4	5	6
6						1	2	3	4	5
7							1	2	3	4
8								1	2	3
9									1	2
10										1

Number of horses to be used for computation shall be those horses actually competing, excluding the number of horses entered but scratched from competition.

Neither a No Score nor a Zero (0) score is eligible to receive points in a Reining Australia Youth class. This does not alter the above scale of points for placing.

## **Rules for Judges**

To rein a horse is not only to guide him, but also to control his every movement. The best reined horse should be willingly guided or controlled with little or no apparent resistance and dictated to completely. Any movement on his own must be considered a lack of control. All deviations from the exact written pattern must be considered a lack of/or temporary loss of control and therefore a fault that must be marked down according to severity of deviation. After deducting all faults, set here within, against execution of the pattern and the horse's overall performance, credit should be given for smoothness, finesse, attitude, quickness, and authority of performing various manoeuvres, while using controlled speed which raises the difficulty level and makes him more exciting and pleasing to watch to an audience.

*(Author: Jim Willoughby)*

## **Reining Australia Judging Privileges**

Designation as an RA approved judge is a privilege, not a right, bestowed by the RA Board, according to procedures formulated by the RA Judges Committee.

This privilege shall be open to individuals whose equine experience and expertise, as well as personal character, merits the honour. An individual's conduct as a member, exhibitor, and judge, and his or her ability must be exemplary. An individual's conduct will be subjected to continuous committee review.

- (a) All prospective judges and refresher judges must participate in the RA Judges Seminar. Upon passing the testing requirements, those persons will then have their names submitted to the RA Board and if approved will be listed on the RA Website.
- (b) The applicant must be at least twenty-five (25) years of age and must have been an RA member in good standing for 24 months within the preceding 3-year period prior to the date of application before the applicant can be considered for approval as an RA judge. It will be at the discretion of the RA Judges committee and RA Board to accept an application to accredit judges in consideration of exceptional circumstances
- (c) Approved/refresher judges are required to be current RA members.
- (d) It is mandatory that all approved RA judges submit to re-testing every two (2) years.

## **Performance Review and Monitoring of Judges**

Performance reviews may be requested through the Judges Assessment and Monitoring System (JAMS). All reviews performed through the JAM System are non-punitive in nature and will be used for the education and improvement of RA judges. Reviews will be contingent upon the availability of official show video. Non-approved classes or events will not be evaluated.

The Judges Executive Committee and/or the RA Board have the right to deny a request for review. Parties requesting the review do not receive the results of the review unless it is a review of one's own judging performance.

A request for review must be accompanied by \$100 lodgement fee

## **Judges Fees**

Judge's fees should be negotiated with Affiliates. Refer to Judges Committee for recommendations.

**Judges Policy and Procedure and Judges Committee Terms of Reference can be found on the RA Website.**

**The Judges Directory can be found on the RA Website under the Contact Us tab.**

- (1) A horse may not be shown under a judge, if that judge has been owner, exhibitor, trainer, or agent of that horse within the previous 90 days or if said horse is ridden by a member of his immediate family or by an employee/ employer of said judge.
- (2) A judge may not show to another judge whom he has judged within five days, nor may a Judge judge another judge to whom he has shown or judged within five days. Volunteer judges utilised for equipment inspection are excluded.
- (3) A judge is responsible for disclosing an agency relationship as soon as he becomes aware of the problem to the show representative if a horse is exhibited not in compliance with the above.

The judge should notify the show representative or show management at the next break, drag or prior to the class being placed of the non-compliance. The exhibitor should not be counted as an entry, and the horse shall not be scored in the class. All parties involved including but not limited to the owner, exhibitor, and judge will be held responsible in the event non-compliance.



- (4) Individuals with an ongoing (regular, continuous, or contractual) business relationship within 90 days where services are paid for by either party should not judge or be judged by each other; this relationship applies to both exhibitor and owner.
- (5) A Judge shall not be an exhibitor at any RA approved event or combination of events at which he or she is the officiating judge. Volunteer judges utilized for equipment inspection are excluded.
- (6) Judges shall keep in mind that while judging they are representing RA; it is strongly recommended that judges dress appropriately so as to favourably represent their position.
- (7) It is recommended that a judge shall not appear on the show grounds more than one-hour prior to the scheduled start of the show unless directed or requested by show management. Judges shall not visit owners, trainers, exhibitors, or agents before or during the event. Judges shall talk only with representatives of show management, beyond the exchange of normal greeting, until the end of the show.
- (8) A Judge must present in writing any grievance within 10 days of the incident that he/she may have against contestants or shows to RA Office, a judge is not required to post the \$100 grievance fee. Any grievance against a judge must also be reported to the RA Office and accompanied by the \$100 protest fee. Any grievance concerning a judge's conduct must be filed within ten days of having gained knowledge of the incident. All grievances will be dealt with in accordance with the disciplinary procedure.
- (9) A judge shall conduct himself/herself in a manner fitting and proper to one afforded the honour of officiating at any RA approved event. Any misconduct on the part of the judge at any RA event such as drinking immediately prior to or during the event, use of abusive language, or any other action unbecoming to one in his/her position either on the grounds or elsewhere during the duration of the show will make him/her subject to a complete and impartial hearing on the cause of the complaint before the appropriate committee.

- (10) A judge who undertakes the obligation to officiate at a sanctioned event is responsible to fulfil that commitment. Should he/she be unable to officiate for any reason, he/she is required to arrange for a suitable qualified replacement. Judges are also required to notify the RA Office. Failure to do so, for any reason, will result in immediate suspension of judging privileges.
- (11) Any Authorized board, club or show committee member who is not competing at a show may hire/contract the judge(s) for the Show.
- (12) A reining will be complete, and the posted scores will be considered official thirty (30) minutes following the last horse of the day. Scores must be posted or made available to exhibitors prior to the judge leaving the grounds for the day. Corrections to a judge's score cards cannot be made once the judge leaves the grounds. Corrections to results due to inputting errors may be made any time.

## (1) Scoring

The scoring will be on a basis of zero (0) to infinity, with seventy (70) denoting an average performance. The individual manoeuvres are scored in one-half (½) point increments from a low of -1½ (minus one and one-half) to a high of +1½ (plus one and one-half) with a score of zero (0) denoting a manoeuvre that is correct with no degree of difficulty. Total scores will be announced after each horse works.

-1½ Extremely poor	+½ Good
-1 Very poor	+1 Very Good
-½ Poor	+1 ½ Excellent
0 Correct	

## (2) Ties

All ties for 1st place will be worked off if the tied exhibitors agree to participate in a run-off.

Tied exhibitors have the alternate option of agreeing not to run-off and to be named co-champions but must determine the winner of the awards by a mutually agreed upon tiebreaker such as a flip of a coin. If they do not agree, the exhibitor(s) who does not want to run-off will forfeit first place to the other. (Exception: Freestyle reining.)

*Note: In Snaffle Bit or Hackamore classes, a run-off is not required for 1st place.*

In the case of a tie, the exhibitors or representatives shall be at the gate by the completion of the class to notify show management if they wish to run-off or remain co-champions. If the riders decide to have a run-off all riders involved in the tie must be present, with their horses, and ready to enter the pen within a maximum of ten minutes after the last horse in the class exits the pen. If one or all of the horses involved in the tie competed within the last five runs of the class, it will be up to the judge's and show management's discretion on the amount of time the rider has before competing in the run-off.

If a tie occurs after the run-off, the entrants will be named co-champions and will evenly split the prize money. If a tie occurs after the run-off, the entrants will be named co-champions; will evenly split the prize money from their placings but must determine the winner of the awards by a mutually agreed upon tiebreaker such as a flip of a coin. A horse not returning for a run-off without such an agreement will forfeit 1st place prize money regardless of the added money.

In the case of a run-off, the contestant(s) not winning the run-off cannot be placed lower than the lowest position for which he/she was tied, i.e., 2nd/3rd.

All other ties are not worked off and will involve as many places as there are horses tied, i.e., 4th, 5th, 6th, 7th. The prize money in the above-mentioned example is added together and split equally, four ways.

### **(3) Equipment**

- (a) References to hackamore mean the use of a flexible, braided, rawhide, leather, or rope bosal, the core of which may be either rawhide or flexible cable with a maximum diameter of 2 cm (3/4") at the cheek.

Absolutely no rigid material will be permitted under the jaws or on the noseband in connection with the bosal, regardless of how padded or covered. Horsehair bosals are Prohibited. This rule does not refer to the so-called mechanical hackamore which is illegal.

- (b) References to snaffle bits mean conventional O-ring, egg-butt, or D-ring with a ring no larger than 10 cm (4") and no smaller than 5 cm (2").

The inside circumference of the ring must be free of rein, curb, or headstall attachments which would provide leverage. The mouthpiece should be round, oval, or egg-shaped, smooth, and free of wire. It may be inlaid, but smooth and/or latex wrapped. The bars must be a minimum of 8 mm (5/16") in diameter, measured 2.5 cm (1") in from the cheek. These requirements remain the same for all classes in which a rider may use a snaffle bit.

- (c) References to a bit means the use of a curb bit that has a solid or broken mouthpiece has shanks and acts with leverage.

All curb bits must be free of mechanical device and should be considered a standard western bit. A standard western bit includes:

1. 21.5 cm (8.5") maximum length shank to be measured as indicated in the judge's guide. Shanks may be fixed or loose.
2. Concerning mouthpieces, bars must be round, oval, or egg-shaped, smooth, and free of wire, of 8 mm (5/16") to 2 cm (3/4") in diameter, measured 2.5 cm (1") from the cheek. They may be inlaid but must be smooth or latex wrapped. Nothing may protrude more than 3 mm (1/8") below the mouthpiece (bar).
3. The port must be no higher than 9 cm maximum, with rollers and covers acceptable. Broken mouthpieces, half breeds, and spades are standard. Spade bits may have wire wrapped spacer bars.

4. Slip or gag bits, donuts or flat polo mouthpieces are not acceptable.
  5. A standard western bit has only one point of pull.
- (d) Rein handling: Only one hand may be used on the reins and the hand must not be changed, except in the Snaffle Bit, Freestyle, Green Rider, non-sanctioned and Para-Reining classes which allow the use of two hands.

In Green Rider, non-sanctioned and Para-Reining classes, riders may use one (1) or two (2) hands on the reins or change from one-handed to two-handed throughout the performance. When showing one-handed, the hand must be held in a traditional western fashion with the palm down and on top of the reins. Index/first finger only, or no fingers, between split reins is permitted at any time. Violation of this rule results in a penalty score of zero (0).

- (e) When a curb bit is used, a curb strap or curb chain is required, which must be at least (1.25 cm) (½") in width, lie flat against the jaw, and be free of barbs, wire, and/or twists.
- (f) Tails may be lengthened by hair-to-hair attachment only with no attachment of any kind to the tail bone. The use of weighted tails is legal.

#### **(4) Penalties: No Score**

The following will result in No Score:

- (a) Infraction of any state or federal law which exists pertaining to the exhibition, care and custody of horses within the state or country where an RA Reining is being held.
- (b) Abuse of an animal in the show arena and/or evidence that an act of abuse has occurred prior to or during the exhibition of a horse in competition.
  - (i) If the judge(s) determines paint or other substance has been applied to a horse to disguise abuse, he/she may call a NO SCORE. Excessive use of paint or colour substance may result in a no score.
- (c) Use of illegal equipment, including wire on bits, bosals, or curb chains.
- (d) Use of illegal bits, bosals, or curb chains.
- (e) Use of tack collars, tie downs or nose bands.
- (f) Use of whips or bats.
- (g) Use of any attachment which alters the movement of or circulation to the tail.

- (h) Use of belly bands, belly wraps, or other materials wrapped around the belly.
- (i) Failure to dismount and/or present horse and equipment to the appropriate judge for inspection.
- (j) In any approved class, the judge shall have the authority to require the removal or alteration of any piece of equipment or accoutrement, which is unsafe, or in his / her opinion, would tend to give a horse unfair advantage or which he/she believes to be inhumane.
- (k) Disrespect or misconduct by the exhibitor.
- (l) The judge(s) may excuse a horse at any time while in the arena for unsafe conditions or improper exhibition pertaining to both the horse and/or rider.
- (m) Closed reins are not allowed except as standard romal reins and as mecates on snaffle bits and bosals in classes where the use of two hands is allowed and in the Youth 10 & Under Short Stirrup, Para-Reining, and Green Rider classes where closed reins are allowed.
- (n) Use of Bluetooth headsets or electronic devices, excluding Para-Reining.

#### **(5) Penalties: Excess rein**

Excess rein may be straightened anytime during the pattern, provided the rider's free hand remains behind the rein hand. Any attempt to alter tension or length of the reins from bridle to the rein hand is to be considered use of two hands a penalty score of zero will be applied.

In addition, should the judge determine the free hand is being used to instil fear or praise, a penalty five will be applied, and a reduction in the manoeuvre score. When using a romal, the rider's hand shall be around the reins with the wrist kept straight and relaxed, the thumb on top and the hand closed around the reins, no fingers between the reins are allowed. The free hand may be used to hold the romal provided it is held in a relaxed position and there is at least 40 cm of romal from the free hand to the reining hand. Use of the free hand while holding the romal to alter the tension or length of the reins from the bridle to the reining hand is considered to be the use of two hands, and a score of zero (0) will be applied with the exception of any place a horse is allowed to be completely stopped during a pattern.

A rider must be allowed to untangle or straighten the horse's mane at any place a horse is allowed to be completely stopped during a pattern.

**(6) Penalties: Exhibitor number**

The following will result in a \$25 fine: Failure to display exhibitor number or displaying incorrect exhibitor number.

**(7) Penalties: Score of Zero (0)**

The following will result in a penalty score of Zero (0):

- (a) Use of more than index or first finger between reins.
- (b) Use of two (2) hands (exception in Snaffle Bit, Hackamore, Para-Reining, Freestyle, or Green Rider classes).
- (c) Use of romal other than as outlined in (5).
- (d) Failure to complete the pattern as written.
- (e) Performing the manoeuvres other than in specified order or exceeding greater than one quarter of the circle out of order.
- (f) The inclusion of manoeuvres not specified, including, but not limited to:
  - 1. Backing more than two (2) strides.
  - 2. Turning more than ninety (90) degrees.
  - 3. On run in patterns, once beginning a lope, coming to a complete stop prior to reaching the first marker.

*(Exception: A complete stop in the 1st quarter (1/4) of a circle after a lope departure is not to be considered an inclusion of manoeuvre; a two (2) point breaks of gait penalty will apply.)*

- (g) Equipment failure that delays completion of pattern.
- (h) Balking or refusal of command where performance is delayed.
- (i) Running away or failing to guide where it becomes impossible to discern whether the entry is on pattern.
- (j) Jogging in excess of one-half (1/2) circle or one-half (1/2) the length of the arena.
- (k) Over-spins of more than one quarter (1/4) turn.
- (l) Fall to the ground by horse or rider. A horse is deemed to have fallen when its shoulder and /or hip and/or underline touches the ground.
- (m) Dropping a rein that contacts the ground while the horse is in motion.
- (n) Failure to wear appropriate western attire as outlined above.
- (o) When going to and coming out of a rollback in a pattern requiring a run-around, a rollback that crosses the centre line.

NOTE: Neither a No Score nor a Zero (0) is eligible to place in a go-round or a single go-round class. Neither a No Score nor a Zero (0) may advance in a multi-go event.

NOTE: In multi-go events, finals qualifying horses that get a Zero (0) or scratch will still be eligible for payouts, with a Zero (0) placing higher than a scratch. In the event not enough horses qualify for total purse distribution, the undistributed portion of the purse will be retained by show management.

### **(8) Penalties: Five (5) point penalty**

The following will result in a penalty of five (5) points:

- (a) Spurring in front of cinch.
- (b) Use of either hand to instil fear or praise.
- (c) Holding saddle with either hand.
  - Exceptions:
    1. Freestyle Reining
    2. Youth 10 & Under Short Stirrup
    3. Age 65 and older (Non-Pro classes only, excluding Aged events)
- (d) The act of a horse dropping to its knees or hocks.
- (e) Blatant disobedience including, but not limited to, kicking, biting, bucking, rearing and striking.

### **(9) Penalties: Two (2) point penalty**

The following will result in a two (2) point penalty:

- (a) Break of gait. (Note: Simple lead changes are allowed in Green Rider and Para-Reining classes, no break of gait penalty should be applied during the lead change.)
- (b) Freezing up in spins or rollbacks.
- (c) On walk in patterns, loping prior to reaching the centre of the arena and/or failure to stop or walk before executing a lope departure.
- (d) On run in patterns, failure to be in a lope prior to reaching the first marker or break of gait prior to the first marker.
- (e) If a horse does not completely pass the specified marker before initiating a stop position.

### **(10) Penalties: Out of lead**

Starting or performing circles or eights out of lead will be judged as follows:

- (a) Each time a horse is out of lead, a judge is required to penalize by one (1) point. The penalty for being out of lead is cumulative, and the judge will add one (1) penalty point for each one quarter (1/4) of the circumference of a circle or any part thereof that a horse is out of lead.



- (b) A judge is required to penalize a horse one half ( $\frac{1}{2}$ ) of a point for a delayed change of lead by one (1) stride where the lead change is required by the pattern description.
- (c) In patterns requiring a run-around, failure to be on the correct lead when rounding the end of the arena will be penalized as follows:
  - (i) From the turn to the half-way position at the end wall: one (1) point
  - (ii) Beyond the half-way point to the beginning of the run down: two (2) points

**(11) Penalties: Jogging**

- (a) Deduct one half ( $\frac{1}{2}$ ) point for starting a circle at a jog or exiting rollbacks at a jog up to two (2) strides.
- (b) For exiting rollbacks at a jog beyond two (2) strides but less than one half ( $\frac{1}{2}$ ) circle or one half ( $\frac{1}{2}$ ) the length of the arena, deduct two (2) points.

**(12) Penalties: Under- and over-spin**

- (a) Deduct one half ( $\frac{1}{2}$ ) point for over or under spinning up to one eighth ( $\frac{1}{8}$ ) of a turn.
- (b) Deduct one (1) point for over or under spinning up to one quarter ( $\frac{1}{4}$ ) of a turn.

A horse can only be assessed one over or under spin penalty per manoeuvre.

**(13) Penalties: Side wall and centre**

- (a) There will be a one half ( $\frac{1}{2}$ ) point penalty for failure to remain a minimum of six (6) metres from the side of the arena when approaching a stop and/or rollback.
- (b) In a pattern requiring a run-around, there will be a one half ( $\frac{1}{2}$ ) point penalty for failure to remain a minimum of 3 metres from either side of the centre of the arena when approaching a stop and/or rollback. For small arenas, the distance will be at the judge's discretion.

**(14) Deduction for stumbling**

A horse which severely stumbles, significantly detracting from the manoeuvre, shall have the manoeuvre reduced by one half ( $\frac{1}{2}$ ) point.

**(15) Horse and equipment check**

All riders must dismount, and the horse must be presented, and the bridle dropped by the rider or a designated representative. The horse and equipment must be checked by the designated judge in the arena or in close proximity to the arena during a pre- or post-check. Should the equipment judge detect cause for a no score (see 4), the exhibitor or his/her representative, trainer or guardian has two options.

(a) They may accept the no score and allow the equipment judge to cause the appropriate changes to all score cards, or  
(b) request the other judges confer on the appropriate call.  
In the case of a youth exhibitor, should a parent, trainer or guardian not be present, it will be assumed that all parties are aware of this rule and agree to abide by the exhibitor's decision. If requested, the equipment judge will confer with the other judges as soon as practical. Failure to comply with this rule shall result in a no score.

### **(16) Reviews**

An exhibitor or owner in the respective class may request a review of a major Penalty (penalty score zero (0) a five (5) point, or a two (2) point penalty). The judge(s) has the right to deny or honour the request. If honoured by the judge(s), he/she must believe the entire class was videotaped by an official videographer. The request must be made no later than thirty (30) minutes after the last run of the day and before the judge(s) have left the grounds for the day. Exhibitors or owners may not have direct contact with the judge(s) during the entire process of requesting a review. The request must be submitted to the Show Representative, or if need be, Show management who will take the request to the judge(s).

### **(17) Re-rides**

The judge has the option of awarding a re-ride if an unavoidable circumstance disrupts a horse and rider's pattern. In the instance where a re-ride is warranted in the judge's opinion, the judge should advise the RA Representative and/or horse show management of this as soon as possible. In the case where a horse was able to complete the pattern, but a re-ride is warranted, the score should be held until the rider decides whether to exercise the re-ride options.

### **(18) Use of aids by challenged riders**

The Judges Committee will evaluate individual requests from challenged riders regarding the use of aids when exhibiting. In the event an individual is granted special privileges, said privileges will be presented in writing and a copy must be provided to the Show Committee each time he or she exhibits. The Show Committee is required to present said privileges to the Judge(s) with the individual's draw number and exhibitor number prior to the class in which he or she will be competing.

**Judges shall be the sole persons responsible to determine if a rider has correctly completed the pattern as written.**

## **Para Reining**

Para Reining is open to riders with physical disabilities or intellectual impairment. The rider must provide RA with a current Para Reining Physicians Statement. RA will determine approval of Para status and upon approval provide the rider with a RA Para Reining Card which must be submitted to any Show Secretary with Show entries.

### *Allowances*

- (a) In Para Reining, a rider may ride up to but no more than three (3) horses per class. A horse may be shown a maximum of two (2) times in the same class under different Para Reining riders.
- (b) The use of a certified helmet is mandatory in all Para Reining classes and/or any time a Para Reining rider is mounted.
- (c) Para Reining classes may not have added money.
- (d) All Riders must be RA members; Green Rider membership is acceptable.
- (e) Horses do not have to have an RA competition license prior to showing in a Para Reining class.
- (f) Judge's fee cannot exceed the entry fee.
- (g) Show Management can retain any percentage of the entry fees.
- (h) Riders may use reining patterns or other relaxed patterns meeting the following guidelines:  
Required manoeuvres include at least one sliding stop, one circle in each direction, a minimum of two spins to the left and two spins to the right.
- (i) Riders may choose the size and speed of the circles when it is not specified in the pattern. Excessive speed will result in a manoeuvre deduction. Gaits may include a walk, jog and/or lope. Show management is responsible for informing the Judge of the relaxed pattern prior to horses being shown.
- (j) Riders may hold the saddle without penalty.
- (k) Closed reins may be used and include but are not limited to romal, roping, crossed, knotted, or taped reins.
- (l) Riders may ride with one or two hands at any time during the class.

- (m) Riders may use the general aids and provisions included in the list below. Provisions outside of the list below will be handled at the discretion of show management.
  - a. Specialty braces and/or belts
  - b. Audio communication equipment
  - c. Trainer/handler present in the arena.
  - d. Boot adaptations
  - e. Rein hand holds.
  - f. Rubber bands
  - g. Saddle blocks
  - h. Wedges and/or cushions
  - i. Safety stirrups
  - j. Seat savers
  - k. Whips
- (n) Para riders are exempted from dismounting during the post-check as long as an assistant is present with a halter and lead rope to aid in the post-check areas.
- (o) Exhibitors may use any style bit. The judge stands as the final decision maker and may deem a bit inhumane and unfit for use in competition.

## **General Judging and Scoring Guidelines**

### **Part 1.**

- (i) The development of suitable and proper standards of performance and judging.
  - (ii) The rules for the conduct of Reining competitions and the rules by which reining horses will be judged.
- The following is intended as a guideline for the application of the rules for judging.*

### **Part 2.**

Included are specific patterns which the reining horse must execute exactly, along with certain rules involving the penalties which are applied if a horse fails to perform these specific patterns as required.

Rules for Judging describes in detail the standard by which a reining should be judged. This description remains unchanged and because of its importance in evaluating a reining horse, is reprinted in full herein. This paragraph clearly defines the quality required of a reining horse and is our strongest tool in providing clear and consistent evaluations of quality.

#### Part 3 - Standard.

To rein a horse is not only to guide him, but also to control his every movement.

The best reined horse should be willingly guided or controlled with little or no apparent resistance and dictated to completely. Any movement on his own must be considered a lack of control. All deviations from the exact written pattern must be considered a lack of or temporary loss of control; and therefore, a fault that must be marked down according to severity of deviation.

After deducting all faults set here within, against execution of the pattern and the horse's overall performance, credit should be given for smoothness, finesse, attitude, quickness, and authority of performing various manoeuvres, while using controlled speed which raises the difficulty level and makes him more exciting and pleasing to watch to an audience.

#### Part 4 - Scoring.

The scoring of reining horses is on a positive numeric scale with 70 denoting an average performance.

Patterns are comprised of several distinct manoeuvre groups which judges are asked to evaluate on an individual basis dependent on execution as dictated by the pattern description and the rules for judging.

The individual manoeuvres are scored in  $\frac{1}{2}$  point increments from a low of  $-1\frac{1}{2}$  (extremely poor quality) to a high of  $+1\frac{1}{2}$  (excellent quality) with a score of 0 denoting a manoeuvre that is correct with no degree of difficulty.

The total of the scores applied to the manoeuvre groups is combined with the starting score of 70 and from this gross manoeuvre score, any penalties are deducted to calculate the horse's final score, which is announced after each horse works.

### Part 5 - Stumbling.

An important non-penalty consideration for judges is a horse stumbling. If the stumble is severe enough to significantly detract from the quality of the manoeuvre, a judge is required to reduce the score  $\frac{1}{2}$  point for that manoeuvre (i.e., very good circles with a +1 evaluation would then become  $+\frac{1}{2}$ ).

### Part 6 - Correct exhibitor number.

All horses must display the correct exhibitor number. Failure to display the number, or displaying the wrong exhibitor number, may incur a fine (\$25); this will be at the discretion of show management.

### Part 7 - Challenged riders.

It is important to provide challenged riders with the opportunity to compete on a fair basis. The Judges Committee will evaluate individual requests from challenged riders regarding the use of aids while they exhibit.

If an individual is granted special privileges, then he/she will be presented said privileges in writing and must provide a copy of the letter to the show management each time he/she exhibits. The show management is required to present this copy to the judge(s) as well as the individual's draw number and exhibitor number prior to each class in which he/she will be competing. While allowing for the use of the approved aid(s), judge(s) are required to apply penalties and evaluate manoeuvres in accordance with guidelines.

## **Penalty Application**

### Part 1.

The above describes the manner in which a judge evaluates and scores a horse's execution of manoeuvres. In addition, certain penalties which are applied should a horse fail to execute a precise manoeuvre or deviate from performing the exact, written pattern. These penalties, as mentioned above, are subtracted from the score which the judge has awarded the horse, and thus have a negative impact on the final score the horse receives.

No judge is empowered to change or alter the specific penalties listed. The judge's function is to determine whether a penalty has occurred and to apply the appropriate penalty in each instance.

In every instance, the horse should receive the benefit of any doubt when these penalties are applied. Therefore, if a judge is uncertain as to whether a horse has incurred a specific penalty, the penalty should not be applied. The application of all penalties is not a qualitative determination (i.e., there is no good or bad way to incur an over spin). Manoeuvre evaluations and penalty applications are always to be determined independently.

Part 2.

It is equally imperative that every judge gives benefit of any doubt he/she may have to the exhibitor when assessing whether in fact a penalty has occurred.

### **Equipment Check**

Part 1.

Riders are required to dismount and drop the bridle for inspection before or after showing, either in the arena for a judge or in close proximity to the arena for the designated judge in multiple judge situations. Failure to comply with this rule shall result in a no score. Judges are required to call all occurrences of illegal equipment, unsportsmanlike conduct and evidence of abuse without fail. As with any penalty application, judges are advised that should there be any doubt as to whether or not there has been a violation, benefit of this doubt shall always go to the contestant. Also, judges are advised not to drop or assist in dropping bridles for contestants; this is to be done by the contestant or his/her designated assistant. A judge has the authority to perform random mouth checks. A judge who serves as a volunteer equipment judge is allowed to compete in another class at that show.

Part 2.

Should the judge responsible for examining horses and equipment determine that a rule violation has occurred, that results in a no score the exhibitor or his/her representative, trainer or guardian may at that time accept the no score and allow the equipment judge to cause the appropriate changes to all score cards or request the other judges confer on the appropriate call. If contested, the equipment judge should so indicate to the other judges immediately and detain the horse and equipment until it is possible for the other judges to complete an inspection of said violation.

In a multiple judge situation where the equipment judge is located outside the arena, any infraction detected by the equipment judge should be examined by all other judges as soon as is practical if contested by the exhibitor.

### **Penalty No Score**

#### Part 1.

Horses are to be disqualified and receive a no score if the infractions of “abuse of a horse or misconduct by the rider” are incurred. Misconduct may include failure to present the horse and equipment for inspection after completing the pattern and/or any disrespectful or unprofessional conduct by the exhibitor. This includes not dismounting prior to dropping the bridle.

#### Part 2.

While the application of a penalty for abuse requires the discretion of the judge, this judge must make his/her determination based on the relevant guidelines. The exhibition of a horse that is obviously lame or is otherwise in an unhealthy condition must be considered abuse. Obvious lameness is a clearly evident gait deficit which is:

- (a) Consistently observable at a jog under all circumstances, and/or
- (b) Obvious at a walk, and/or
- (c) Minimal weight bearing in motion and/or rest, or a complete inability to move.

The exhibition of a horse that has a cut or abrasion showing clear evidence of fresh blood in the mouth, nose, chin, shoulder, barrel, flank, or hip area (those areas reasonable to believe the injury may have been caused by the rider or equipment) must be considered abuse regardless of how the injury was caused.

#### Part 3.

Included in the infraction of abuse is the use of illegal equipment. The following are specified as illegal equipment:

- (a) Bits and snaffle bits with mechanical devices.
- (b) Leveraged bits and snaffle bits having mouthpieces constructed from anything other than smooth rounded material. (*Note: Twisted wire mouthpieces are illegal.*)
- (c) Leveraged bits with mouthpiece bar spaces less than 8 mm or greater than 2 cm diameter.
- (d) Bits with protrusions of more than 3 mm below the mouthpiece (bar).



- (e) Bits with ports exceeding 9 cm in height.
- (f) Snaffle bits with rings smaller than 5 cm or larger than 10 cm in diameter.
- (g) Snaffle bits with mouthpieces smaller than 8 mm, measured 2.5 cm from the cheek.

(Note: It should be noted that a conventional snaffle can only be broken in one place. A conventional snaffle may have loose rings. An optional curb strap is acceptable provided it is loose, however, curb chains are not acceptable. No minimum or maximum width is required, decorative knots and round material are acceptable.)

- (h) Rope or leather bosals with wire, iron, or mechanical devices.
- (i) Bosal larger than 2 cm diameter on the cheek.
- (j) Twisted curb chains or curb chains with barbs and/or wire.
- (k) Wire on bits. (Note: Spade bits may have wire wrap on spacer bar only.)
- (l) When a curb bit is used, a curb chain or strap is required.
- (m) Use of tack collars, tie downs, nose bands, electric shocks, whips, or bats.
- (n) Use of any attachment which alters the movement of or circulation of the tail.
- (o) Use of Bluetooth headsets or electronic devices, excluding Para Reining.

Note: In any approved class, the judge(s) shall have the authority to require the removal or alteration of any piece of equipment or accoutrement which is unsafe, which he/she believe to be inhumane, or in which, in his/her opinion, would give a horse an unfair advantage.

#### Part 4.

A judge is thus compelled to disqualify any horse that he/she feels is being exhibited in a manner which is cruel, abusive, and inhumane. This may include the exhibition of an animal which is clearly not in a fit or sound condition, the use of abusive equipment, and/or the use of abusive showing techniques by the rider. A judge(s) may excuse a horse at any time while in the arena for unsafe conditions or improper exhibition caused by the horse and/or the rider. While each judge is required to disqualify any horse exhibited in the manners described above, it should be noted that in every case the exhibitor should be given the benefit of any doubt should any doubt exist.

#### Part 5.

Judges are required to report no score situations to the Show Representative with instructions to include the details of said no score in the official show representatives report. Further, a judge (or judges) must present in writing any grievance that he/she may have against contestants or shows to an official officer, director, or duly elected or appointed contestant's representative of RA at the time of the grievance. It should be noted that a judge is not required to post the grievance fee.

### **Penalty Score Zero**

#### Part 1.

In certain situations, in which a horse will receive a score of zero (0) regardless of its execution of the pattern. These situations shall be reported by a judge to a scribe as "penalty score zero." It is extremely important to avoid confusion in the scribe's recording. It is prohibited to use more than the index/first finger between the reins, the changing of hands on the reins or use of two hands on the reins; however, specific situations are outlined in which the rider's free hand may be used to untangle excess rein. It is also permitted for the rider to use his/her free hand to hold a romal in the normal fashion; the definition of which is contained hereunder. Exceptions occur in the Snaffle Bit & Hackamore, Freestyle, Youth 10 & Under, Green Rider and Para Reining classes.

#### Part 2.

When using a romal, the rider's hand shall be around the reins with the wrist kept straight and relaxed, the thumb on top and the hand closed around the reins; no fingers between the reins are allowed. The free hand may be used to hold the romal provided it is held in a relaxed position and there are at least 40 cm of romal from the free hand to the reining hand. Use of the free hand while holding the romal to alter the tension or length of the reins from the bridle to the reining hand is considered to be the use of two hands and a score of zero (0) will be applied. Regarding split reins, a rider using a romal may untangle excess rein (romal) anytime during the pattern, provided the rider's free hand remains behind the rein hand. A rider must be allowed to untangle or straighten the horse's mane at any place a horse is allowed to be completely stopped during a pattern.

#### Part 3.

A penalty score zero (0) shall also be incurred if a horse fails to complete the pattern as written, performs the manoeuvres in other than the specified order, and/or includes manoeuvres

not specified. Included as manoeuvres in “other than the specified order” is the situation wherein a horse runs circles out of order, or exceeds greater than one quarter of the circle out of order (i.e., when a small slow and large fast circle are required and the horse runs a large fast and small slow and large fast set of circles, or when it requires a large fast, a lead change and a small slow and the horse runs a large fast, does a lead change, and then continues over one quarter of the next circle in a large fast), and on run in patterns, once beginning a lope, coming to a complete stop prior to reaching the first marker. When going to and coming out of a rollback in a pattern requiring a run around, a rollback which crosses the centreline of the arena will result in a penalty score zero (0). In the instance where a horse backs up where a backup is not specified, the penalty score of zero (0) will be incurred should the horse back more than two (2) full strides. It is important to note one stride is defined as the complete movement or steps of all four legs, one time. In this situation it is very helpful for a judge to watch and count the steps of the front feet. Up to and including four (4) steps of the front feet in the non-required backup receives no penalty. The horse must complete five (5) or more consecutive steps backward without stepping forward to be considered an inclusion of a manoeuvre. Whenever a horse deviates from the exact written pattern by turning more than 1/4 of the geographical circumference of the arena (i.e., an over spin, a turn during a backup, etc.), the penalty score of zero (0) will be applied. When a horse stops (completely losing forward motion) where a stop is not required, an inclusion of manoeuvre has occurred and a penalty score of zero (0) will be applied. There is an exception to this rule; a complete stop in the first 1/4 circumference of a circle after a lope departure is not to be considered an inclusion of manoeuvre. This allows for a rider to correct a missed lead. It is important to be sure that all other penalties incurred during this situation are applied, including jogging, missed leads, and always a break of gait in lieu of the inclusion of manoeuvre.

#### Part 4.

A refusal of a command (balk) will incur a penalty score of zero (0). In this instance, the judge must determine that the horse blatantly and continuously refused a rider's command. In the case of a spin or a rollback, the judge must differentiate between freeze up (as discussed below) and refusal of command. The Rule Book further states that a penalty score of zero (0) will be applied if a horse jogs in excess of 1/2 of the circumference of a circle, or 1/2 the length of the arena.

(This does not apply to pattern #11 which is a jog-in pattern and requires a horse to jog the majority [over 1/2 the distance] of the way to the centre.)

The Rule Book also requires judges to apply a penalty score of zero (0) in the event that a horse or rider falls to the ground, or the rider is dislodged. A horse is deemed to have fallen when its shoulder and/or hip and/or underline touches the ground.

The Rule Book also specifies that each entry must run in order drawn.

Note: In multi-go events, finals qualifying horses that get a zero (0) score or scratch will still be eligible for payouts, with a zero (0) score placing higher than a scratch. In the event not enough horses qualify for total purse distribution, the undistributed portion of the purse will be retained by show management.

### **Five Point Penalties**

#### Part 1.

There are five situations that require a judge to apply a five (5) point penalty. These situations are:

- (a) Spurring in front of the cinch; the judge is required to ensure that contact with the horse was made.
- (b) Use of either hand to instil fear or praise.
- (c) Holding the saddle with either hand (except in the Freestyle Reining or Youth 10 & Under Short Stirrup class or for riders 65 and older (Non-Pro classes only, excluding Aged Events)).

The holding the saddle rule does not include incidental, brief contact (i.e., brushing the saddle with the free hand). Judges must allow riders to straighten reins at an appropriate place without incurring a holding the saddle or instilling praise penalty.

- (d) The act of a horse dropping to its knees or hocks that cannot be considered a fall since its shoulder and/or hip and/or underline did not touch the ground.
- (e) Blatant disobedience which includes, but not limited to, kicking, biting, bucking, rearing, and striking.

It should be noted that judge(s) may confer and/or review the video on five (5) point penalties. Therefore, it is helpful for judges in multiple judged events to require scribes to

acknowledge the existence of a five (5) point penalty when reporting the score. If a lack of concurrence exists, then show management would be alerted and scores would be held pending video review or conference.

Note: A rider is allowed to untangle or straighten the latigo or horse's mane without incurring a five (5) point penalty any place a horse is allowed to be completely stopped during the pattern.

## **Two Point Penalties**

### **Part 1.**

A judge is required to apply a two (2) point penalty should a horse break gait during the execution of a pattern. The requirement here is to determine gait has been broken, not what gait or if actually a gait was reached by transition. An important consideration is a horse which, while executing a required downward speed transition, has its rear feet briefly slip on the ground without loss of the overall cadence and stride of the lope should not receive a two (2) point break of gait penalty. If gait is clearly broken, it should receive the appropriate two (2) point penalty. Further, should the horse stop during the downward speed transition (completely lose forward motion) an inclusion of manoeuvre will have occurred resulting in a penalty score of zero (0). Judges will be allowed to review two (2) point penalties for break of gait, jogging more than two (2) strides and freeze ups as long as one judge has called the two (2) point penalty (P2). Note: Simple lead changes are allowed in Green Rider classes; no break of gait penalty should be applied during the lead change.

### **Part 2.**

If a horse freezes up in a spin or rollback, a two (2) point penalty will be applied. A freeze up is defined as a brief but obvious refusal to start a spin or rollback or any complete stoppage of a horse's lateral shoulder movement which delays the execution of a spin or rollback. A judge thus must determine whether there was a momentary complete stoppage of lateral shoulder movement in a spin or rollback. It is not necessary to determine if the freeze up was caused by the horse or rider (i.e., a rider who spins 3 times, stops his/her horse, and realizes the error and immediately completes the 4th spin, shall receive a freeze up penalty).

### **Part 3.**

It is required in patterns that begin in the centre of the arena with a lope departure, the departure be executed from a

walk or stopped position; failure to do so shall result in a judge applying a two (2) point penalty. It should be noted that in patterns beginning with spins at the centre of the arena, failure to complete spins in the prescribed area would result in a reduction of the manoeuvre evaluation.

On all run-in patterns, a judge is required to apply a two (2) point penalty for failing to be in a lope prior to reaching the first marker or for a break of gait prior to the first marker.

#### Part 4.

Patterns require a horse to run past a marker placed in the arena prior to stopping. If the horse does not completely pass the specified marker before assuming a stop position, a penalty of two (2) points is to be applied. It is important to note that this penalty is to be applied if the horse assumes a stop position (rear legs up underneath, setting up) whether or not this stop is completed. Further, the judge, by applying this penalty, is only reflecting the fact it happened, and should not be concerned with whether it was caused by the horse or by the rider. Judges should note that it is their responsibility to ensure that these markers are placed correctly, and in such a fashion that a horse could reasonably be expected to go past them before executing a stop or rollback manoeuvre. It is specified that the end markers be no less than 15 metres from the end wall or fence of the arena.

### **Lead Penalties**

#### Part 1.

Each time a horse is out of lead, a judge is required to penalize it by one (1) point. The penalty for being out of a lead is cumulative, and the judge will add one (1) penalty point for each one-quarter of the circumference of a circle or any part thereof that a horse is out of lead. A judge is further required to penalize a horse half ( $\frac{1}{2}$ ) of a point for a change of lead delayed by one stride where a change of lead is required by the pattern. It should be noted that a gait is specified, but no lead is specified in the instance of run downs either on the side of the arena or through the middle of the arena, and no penalty is incurred for a horse changing leads in these areas.

#### Part 2.

In patterns where a horse is required to make a run around the end of the arena, the horse must be on a specific lead while rounding the end of the arena.

The horse is required to be on the specified lead as soon as it completes the 1st straight portion of the run-around and begins to turn the corner of the arena. Failure to be in the correct lead beyond this point will result in the following penalties being assigned:

- (a) From the turn to the halfway position at the end wall: one (1) point.
- (b) Beyond the halfway point up to the beginning of the run down: two (2) points.

It should be noted there is no correct lead on a straight line. Therefore, changing leads in a straight line is not to be penalized, though it may or may not demonstrate resistance to being dictated to completely which must be dealt with in manoeuvre evaluation.

### Part 3.

In the instance where a pattern requires a one-half circle prior to beginning a centre run down to the other end of the arena, failure to be on a specified lead should be penalized as follows:

- (a) Beyond one stride up to one-quarter circumference of circle: one (1) point.
- (b) Beyond one-quarter circumference of circle up to the entire half circle: two (2) points.

## **Jog Penalties**

### Part 1.

In as much as a horse is required to be in a lope throughout the reining pattern, a penalty must be applied for starting a circle or exiting a rollback at a jog. Jogging up to two strides incurs a one-half ( $\frac{1}{2}$ ) point penalty. Jogging beyond two strides will incur a two (2) point penalty. (See Figure #5.) In determining whether a one-half ( $\frac{1}{2}$ ) or two (2) point penalty has been incurred, it is useful for a judge to consider the distance travelled and to count the steps of the rear legs. Four (4) steps and under would represent two or less strides and require a one-half ( $\frac{1}{2}$ ) point penalty; five steps and more, therefore, require a two (2) point penalty.

## **Simple Lead Change Penalties**

### Part 1.

In classes which allow simple lead changes, the ideal change is to jog for one stride to change leads. Any deviation from

the ideal change that takes place in the lead change area as described would not incur a penalty but deserves less credit. In order of decreasing difficulty would be: jogging more than one stride, walking rather than jogging, stopping during the change, and finally, making more than one attempt to execute the change. Penalties would apply if the lead change were early or late just as they would for a flying lead change.

#### Part 2.

Judges should allow one-quarter circle coming into the change and one-quarter circle going past the change as an allowable simple change area (safe zone), with only the out of lead penalties applying. For example, a horse that comes across and takes 3 strides past "centre" to complete the simple change, but before the end of the first quarter, would not get a break of gait penalty but would incur a one point out of lead penalty. The same logic would apply for changes before reaching centre. All penalty applications would apply out of that "safe zone".

### **Spin Penalties**

#### Part 1.

When performing the spin manoeuvre, horses are required to stop and start in a precise direction within the arena. Failure to stop a spin with some portion of the horse's shoulder and hip aligned with the proper position will result in a penalty. A horse can only be assessed one over- or under-spin penalty per manoeuvre. The penalties assigned to over- and under-spinning are as follows:

- (a) Over- or under-spinning beyond a shoulder width and up to  $1/8$  of the circumference of the spin: one-half ( $1/2$ ) point penalty.
- (b) Over- or under-spinning up to  $1/4$  of the circumference of the spin: one (1) point penalty.
- (c) If a horse over-spins by more than  $1/4$  of the circumference of a spin, an additional manoeuvre is deemed to have been included and a penalty score of Zero (0) will be applied.

It should be noted that the shoulder width tolerance applied when determining the first  $1/8$  over- or under-spin should not be applied when determining the severity of the deviation [i.e., the determination of a one-half ( $1/2$ ) point or a one (1) point penalty or the determination of a one (1) point penalty or a Zero (0) score].



- (d) In the instance where a horse under spins by more than 1/4 of the circumference of a spin and is properly realigned before starting the next manoeuvre, it shall be considered a freeze up in the spin and a two (2) point penalty will be assigned.

### **Wall Penalty**

#### **Part 1.**

In patterns that require a horse to run around the end of the arena, it is specified the horse must remain a minimum of 6 metres from the side of the arena when approaching a stop and/or rollback. Failure to do so will result in a one-half (½) point penalty.

### **Centre Penalty**

#### **Part 1.**

In a pattern requiring a run-around, there will be a one-half (½) point penalty for failure to remain a minimum of 3 metres from either side of the centre of the arena; for small arenas, the distance will be at the judge's discretion.

### **Reviews**

#### **Part 1.**

If the judge is unsure as to whether a major penalty has occurred (i.e., no score, a 0 score, a 2-point penalty, or a 5-point penalty) the judge will submit his/her score and ask that the score be held pending a conference or a review of the video at the next drag. Further, it must be remembered that the RA Rule Book does not allow judges to confer as to any penalty or manoeuvre score prior to submitting a score. Video reviews may only be utilized in the instance where the judge believes that all entrants have been videotaped by an official videographer. A judge shall not be required to change his/her score following a conference or video review, each judge's decision is an individual call. Judges will be allowed to review 2-point penalties for break of gait, jogging more than two (2) strides and freeze ups. Upon the review of a major penalty, if the major penalty is deemed to not have occurred, the judge has the ability to add the appropriate penalty.

#### **Part 2.**

Judges must continue to score No Scores and Zero (0) scores in a multiple judged or videotaped event. This allows for video review and/or conference with the other judge(s)

without the potential bias that could exist if a judge should need to reverse his/her original decision or rely on memory to score the run. Whether or not a class is videotaped or multiple judged, it is suggested that judges continue to mark all runs whenever possible, as a service to our members.

### Part 3.

An exhibitor or owner in the respective class may request a review of a major penalty [penalty score Zero (0) and five (5) point penalty, or a two (2) point penalty]. The judge(s) has the right to deny or honour the request. If honoured by the judge(s), he/she must believe the entire class was videotaped by an official videographer. The request must be made no later than 30 minutes after the last run of the day and before the judge(s) has left the grounds for the day. In cases where a class is run in sections over multiple days, each day's scores will be official 30 minutes after the last run of each section. Exhibitors or owners may not have direct contact with the judge(s) during the entire process of requesting a review. The request must be submitted to the Show Representative, or if need, Show Management who will take the request to the judge(s).

## **Descriptions of Manoeuvres**

As mentioned earlier, judges are required to score a reining horse based on its execution of the manoeuvre groups required in each pattern. All patterns are divided into seven (7) or eight (8) manoeuvre groups. Descriptions of ideal manoeuvres required of a reining horse are as follows.

### **WALK-IN**

The walk-in brings the horse from the gate to the centre of the arena to begin its pattern. The horse should appear relaxed and confident. Any action which may create the appearance of intimidation including starting and stopping or checking is a fault which shall be marked down according to the severity in the first manoeuvre score. In a jog-in pattern, horses must jog the majority (more than half) of the distance to the centre. The horse should appear relaxed and confident. Any action which may create the appearance of intimidation including walking, stopping, or checking is a fault which shall be marked down according to the severity in the first manoeuvre score. Failure to jog the majority of the way to the centre will result in a zero (0) score for failure to complete the pattern as written.

## **STOPS**

Stops are the act of slowing the horse from a lope to a stop position by bringing the hind legs under the horse in a locked position sliding on the hind feet. The horse should enter the stop position by bending the back, bringing the hind legs further under the body while maintaining forward motion and ground contact and cadence with front legs. Throughout the stop, the horse should continue in a straight line while maintaining ground contact with the hind feet.

## **SPINS**

Spins are a series of 360-degree turns, executed over a stationary (inside) hind leg. Propulsion for the spin is supplied by the outside rear leg and front legs, and contact should be made with the ground and a front leg. The location of hindquarters should be fixed at the start of the spin and maintained throughout the spins. It is helpful for a judge to watch for the horse to remain in the same location, rather than watching for a stationary inside leg. This allows for easier focus on other elements of the spin (i.e., cadence, attitude, smoothness, finesse, and speed).

## **ROLLBACKS**

Rollbacks are the 180-degree reversal of forward motion completed by running to a stop, rolling (turning) the shoulders back to the opposite direction over the hocks and departing in a lope, as one continuous motion. The Rule Book states no hesitation, however, a slight pause to regain footing or balance should not be deemed hesitation. The horse should not step ahead or backup prior to rolling back.

## **CIRCLES**

Circles are manoeuvres at the lope, of designated size and speed, which demonstrate control, willingness to guide, and degree of difficulty in speed and speed changes. Circles must at all times be run in the geographical area of the arena specified in the pattern description and must have a common centre point. There must be a clearly defined difference in the speed and size of a small, slow circle, and a large, fast circle; also, the speed and size of small, slow right circles should be similar to the small, slow left circles; and the speed and size of the large, fast right circles should be similar to the large, fast left circles.

## **BACKUPS**

A backup is a manoeuvre requiring the horse to be moved in a reverse motion in a straight line a required distance; at least 3 metres.

## **HESITATE**

To hesitate is the act of demonstrating the horse's ability to pause in a relaxed manner, at a designated time in the pattern. All patterns require a hesitation at the end of the final manoeuvre to indicate to the judge(s) the completion of the pattern.

## **LEAD CHANGES**

Lead changes are the act of changing the leading legs of the front and rear pairs of legs, at a lope, when changing the direction travelled. The lead change must be executed at a lope with no change of gait or speed and be performed in the exact geographical position in the arena specified in the pattern description. The change of front and rear leads must take place within the same stride to avoid penalty.

## **RUN DOWNS AND RUN-AROUNDS**

Run downs are runs through the middle of the arena and runs along the side and ends of the arena. Run downs and run-arounds should demonstrate control and gradual increase in speed to the stop.

## **Scoring**

- (1) It is required that the score for each run be reflected on a manoeuvre by manoeuvre and penalty by penalty basis utilizing a scribe and a score sheet. This score sheet represents a judge's report to an exhibitor of how a score was derived, and it is critical that this report to the exhibitor be accurate.
- (2) In the name of accuracy, it is important that the judge not average scores for manoeuvres ([.e., a +½ spin and a -½ spin = two 0 spins, etc.]. A judge must, at the completion of each manoeuvre, evaluate the manoeuvre on the scale listed below as an individual component of the entire run.
- (3) In keeping with this practice, it is also critically important that a judge not average penalties into manoeuvre scores. Penalties are evaluated on a separate criterion than manoeuvre scores and should not at any time be combined with manoeuvre scores [i.e., a +½ spin with a one half (½) point over-spin penalty does not = a zero (0) manoeuvre score]. It is also important for a judge not to allow a penalty to adversely affect the scoring of the manoeuvre unless the quality was truly affected.

- (4) A key element in accurately describing the scoring of the entire run to the exhibitor is the judge's scribe. It is management's responsibility to supply a scribe at every event; however, it is the judge's responsibility to ensure that the scribe is properly trained prior to beginning the first run of the day. The judge must confirm that the scribe understands the fundamentals of recording both manoeuvre scores and penalty scores. It is recommended that judges verify that the addition of the manoeuvre scores and penalties is correct at the completion of the run. The judge should make certain that his/her communications are clear to the scribe and the judge and scribe should agree upon a method of speaking, so that manoeuvre scores and penalty scores are not confused (i.e., a judge will say a number for a manoeuvre score and will say "penalty" and a number for a penalty, thus allowing the scribe to place the appropriate score in the appropriate box on the score sheet). Scribes should be advised to record all scores and penalties in fractions as opposed to decimals to prevent errors in tabulating the final scores. If for any reason a judge does not believe that a scribe is competent, he/she should ask show management to replace the scribe immediately. Judges must sign every completed score sheet.

#### *Manoeuvre scores*

- (1) As described earlier in this guide, each pattern is divided into sets of manoeuvres. It is the judge's responsibility to evaluate these manoeuvre groups individually and rate each manoeuvre group on the following scale:

-1½ Extremely poor	+½ Good
-1 Very poor	+1 Very Good
-½ Poor	+1½ Excellent
0 Correct	

- (2) In evaluating a manoeuvre, a judge should consider the horse's performance based on the following hierarchy of concerns:
- (a) On pattern: The judge must ensure that the manoeuvre being performed by horse and rider is the correct manoeuvre as dictated by pattern.

- (b) Correctness: Having ascertained that the horse and rider are performing the manoeuvre required by the pattern, the judge must then ascertain whether the manoeuvre is being executed correctly.

In this regard, the judge must evaluate the performance of the manoeuvre against the requirements of the manoeuvre descriptions listed in this guide. In each group of manoeuvres, the judge must ascertain that the horse has been dictated to completely and the basic elements of the manoeuvre have been fulfilled regardless of the degree of difficulty. In the instance where horse and rider have failed to correctly perform the manoeuvre, the judge will deduct for a substandard performance. This deduction ranges from  $-\frac{1}{2}$  to  $-1\frac{1}{2}$  for the manoeuvre.

- (c) Degree of difficulty: Having ascertained that the horse and rider are on pattern and have performed the manoeuvre group correctly, a judge must evaluate the degree of difficulty in completing the manoeuvre.

In the instance where the horse has correctly performed the manoeuvre and has exhibited some degree of difficulty, a judge will assess the degree of difficulty on a scale of  $+\frac{1}{2}$  to  $+1\frac{1}{2}$ . Credit for degree of difficulty should be given for using smoothness, finesse, attitude, quickness, authority, and controlled speed while completing a correct manoeuvre.

- (3) It is recommended that a judge use the same scale for evaluating a manoeuvre, regardless of the level of competition at an event and regardless of ground and other conditions. When utilizing the above scoring methodology, it is critically important that judges evaluate the entire manoeuvre group.

For example, in manoeuvre six (6) of pattern #8, a judge is required to evaluate all of the following:

- (a) The run around the end of the arena;
  - (b) The approach to the stop;
  - (c) The stop;
  - (d) The rollback;
  - (e) The exit from the rollback.
- (4) An over emphasis of any component of the manoeuvre group will cause an inaccurate manoeuvre score.
  - (5) It should be noted when applying the previously described hierarchy, that during the various components of a manoeuvre group, a horse and rider may exhibit varying degrees of correctness and difficulty.

Incorrect form in a particular component of the manoeuvre group does not disqualify the horse and rider from correcting the form, therefore being eligible for credit depending on degree of difficulty.

For example, a horse that begins a spin incorrectly for one revolution then corrects the form and achieves a high degree of difficulty in the last three rotations would receive a score for the manoeuvre combining a minus score for the first rotation and a plus score for the final three rotations. Judges are required to generate a manoeuvre score that accurately reflects the combined correctness and degree of difficulty of the various components of a manoeuvre group.

## **Conduct**

### *Misconduct and Re-rides*

- (1) In order to ensure that each and every exhibitor has the unconditional attention of the judge, it is imperative that the judges be allowed to concentrate on the performance of an exhibitor. In this regard, a judge must ensure that show management has provided an environment which provides for said concentration. Should any exhibitor(s) or person(s) in proximity to the show arena conduct him/herself in a manner distracting to the judge, he/she should not continue evaluating horses until the distraction has been removed by show management.
- (2) If the conduct of any exhibitor is disrespectful to a judge, the judge has the right to refuse judging the exhibitor for the remainder of the show and may request show management remove the exhibitor from the show grounds.
- (3) If an unavoidable circumstance (i.e., a fault suddenly appearing in the arena, an unpredictable major distraction to the horse, etc.) disrupts a horse and rider's pattern, the judge may allow for a re-ride. In the event a judge believes that a re-ride is warranted, he/she will ask his/her scribe to inform show management immediately upon completion of the pattern. In the case where a horse was able to complete the pattern, but a re-ride was warranted, the score should be held until the rider decides whether to exercise the re-ride option. An exhibitor who has been allowed a re-ride may choose one of the following options.

- (a) Not re-ride the pattern, and be awarded the score for their original ride, OR
- (b) Re-ride the pattern in an order of go dictated by show management in consultation with judge(s) and accept the score for the second run only.

A horse should never be required to rerun immediately following the original run. Rather, a sufficient amount of time should be given for the horse to rest (approximately 5 minutes). This should prevent a horse from being exhibited while in a fatigued condition.

- (4) Show management, the Show Representative and the exhibitor have no right to petition a judge for a re-ride. Any re-ride must be entirely at the judge's prerogative.

### *Reports and judge's conduct*

- (1) Any person assuming the responsibilities of an RA judge is acting at all times as an RA official. A judge's conduct on and off the show ground must be exemplary and a reflection of the standards required by the Association. A judge's judging privileges may be removed at any time for conduct not considered to reflect favourably upon the Association.
- (2) In the capacity of an official of RA, it is a judge's responsibility to ensure that all deviations from standards by exhibitors or show management be noted on the Show representative's report. This report should include any and all examples of unprofessional conduct by exhibitors, any insufficiencies, or inequities by show management, unsportsmanlike conduct by any individual, and report inhumane treatment of a horse either during exhibition or on the show grounds. It is important that a judge be aware of the name of the Show Representative and to communicate with this individual before and after the show to ensure the Show Representative's report includes any and all concerns of the judge.
- (3) When a judge agrees to officiate at an RA event, he/she is responsible as an official of RA for ensuring that all contractual obligations with show management are both explicit and fulfilled. Any miscommunication between show management and a judge will be deemed by RA to be a judge's responsibility. When a judge agrees to officiate an RA event, it becomes his/her responsibility to ensure the obligation is fulfilled.



If a judge is unable to fulfill the obligation, it is his/her responsibility to ensure that a qualified replacement judge is available under terms suitable to the management of the event. Judges are also required to notify the RA office of said change.

- (4) In order to fully utilize training and judging methodologies, it is imperative that all judges ensure they arrive to officiate at the event in a physically well condition (i.e., well rested, prepared, on time, etc.). Judge(s) shall not appear on the show grounds more than one (1) hour prior to the scheduled start of the show unless as directed by show management.

### **Freestyle Reining – General Rules**

- (1) Freestyle Reining provides an opportunity to use manoeuvres creatively, and also expand them to music by means of choreography. Riders are encouraged to use musical scores which permit them to show the athletic ability of the horse in a crowd appealing way.
- (2) Reining rules will apply except where the following rules pre-empt these rules.
- (3) Required manoeuvres are defined as follows:
  - (a) A minimum of four (4) consecutive spins to the right;
  - (b) A minimum of four (4) consecutive spins to the left;
  - (c) A minimum of three (3) stops;
  - (d) A minimum of one (1) lead change at the lope from right to left;
  - (e) A minimum of one (1) lead change at the lope from left to right.
- (4) Exhibitors will only be judged astride.
- (5) Exhibitors are allowed to use two (2) hands (as well as one or no hands) and any legal bit, including snaffle bits and bosals approved for use in the Snaffle Bit or Hackamore classes.
- (6) Failure to perform all the required manoeuvres or failure to complete the performance within the time limit will result in a score of zero (0).
- (7) Additional manoeuvres such as rollbacks, backups, speed variations, and non-classical reining manoeuvres such as half-pass and side-pass are appropriate in Freestyle and shall be given appropriate credit.

Additional repetitions of required manoeuvres are appropriate but will only add or subtract from the existing scores already given for the required manoeuvres, not as additional scores.

- (8) Equipment used in Freestyle must adhere to the following standards:
  - (a) All equipment must be non-abusive and humane.
  - (b) Any equipment not specifically covered by or in conflict with standard equipment guidelines must be non-abusive to the horse.
- (9) Time Limit. A maximum of four (4) minutes. The time limit will begin when the music starts.
- (10) Length of introductions will be at the discretion of the show staff.
- (11) Costumes are permitted but not required. Emphasis is placed on performing the reining manoeuvres to music. The use of props will not add to the score.

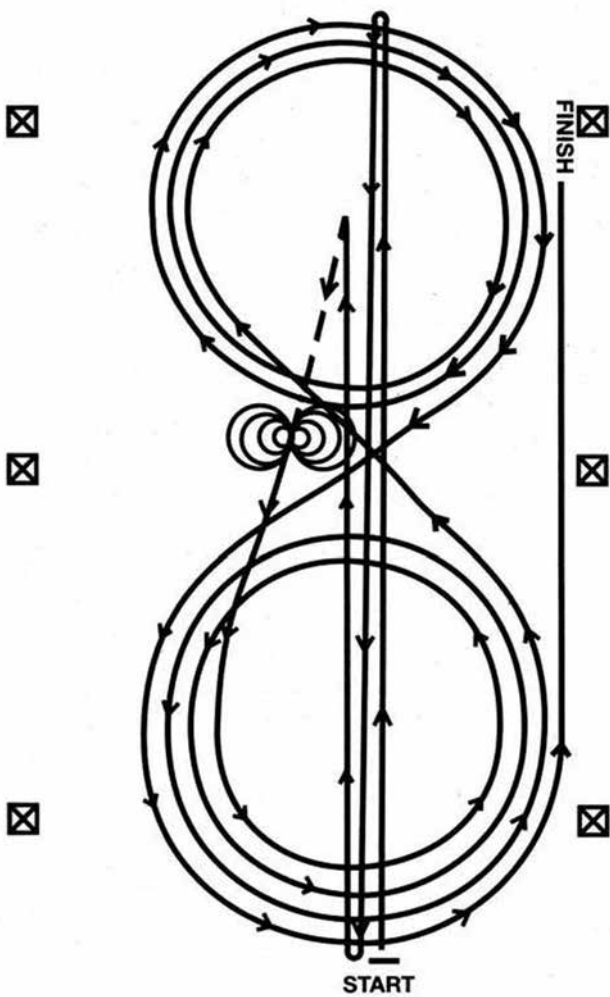
## **Reining Patterns**

1. The following patterns are to be worked as stated, not as drawn. The drawn pattern is just to give the general idea of what the pattern will look like in the arena.
2. Markers will be placed on the wall or fence of the arena as follows:
  - (i) at the centre of the arena;
  - (ii) at least 15 metres from each end wall.
3. Where designated in the pattern for stops to be beyond a marker, the horse should begin his stop after he passes the specified marker.
4. Each pattern is drawn so that the bottom of the page represents the end of the arena entered by contestants and must be run as such. In the event that an arena has only one gate and it is in the exact middle of the side, that side shall represent the right side of the page the pattern is drawn on.
5. All horses will be judged immediately upon entering the arena and judging will cease after the last manoeuvre. Any fault incurred prior to the commencement of a pattern will be scored according to the rules for judging.
6. All judges' decisions are final.

For more information and questions  
Please contact the Reining Australia Office  
Lynda Gray Office Manager

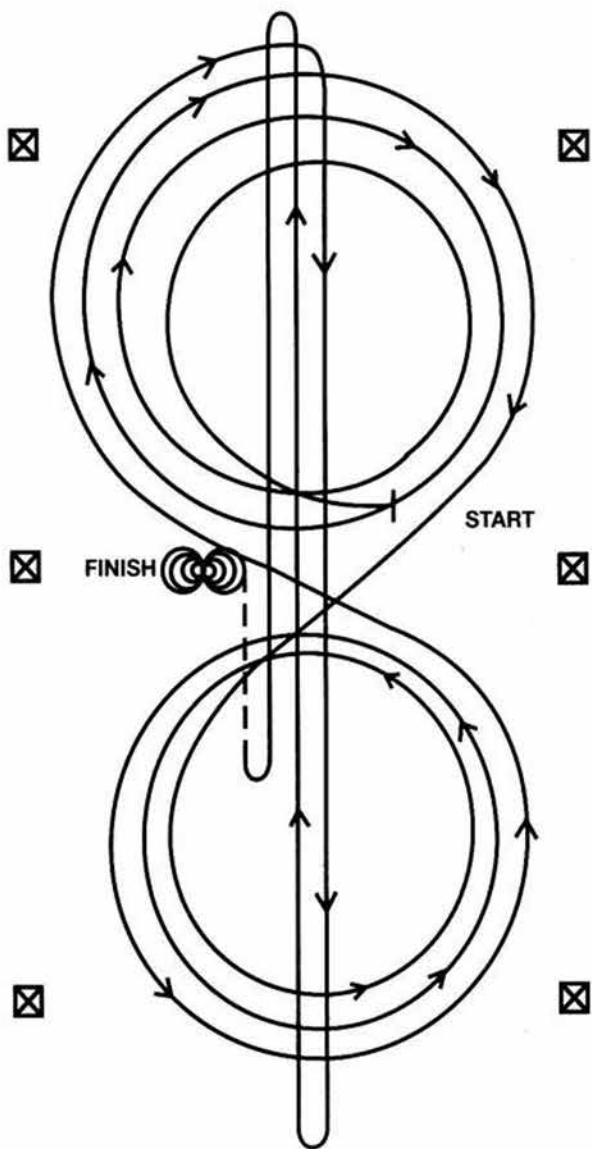
secretary.reiningaustralia@bigpond.com  
Website. [www.reiningaustralia.com.au](http://www.reiningaustralia.com.au)

Phone 0412 479 340



## **PATTERN 1**

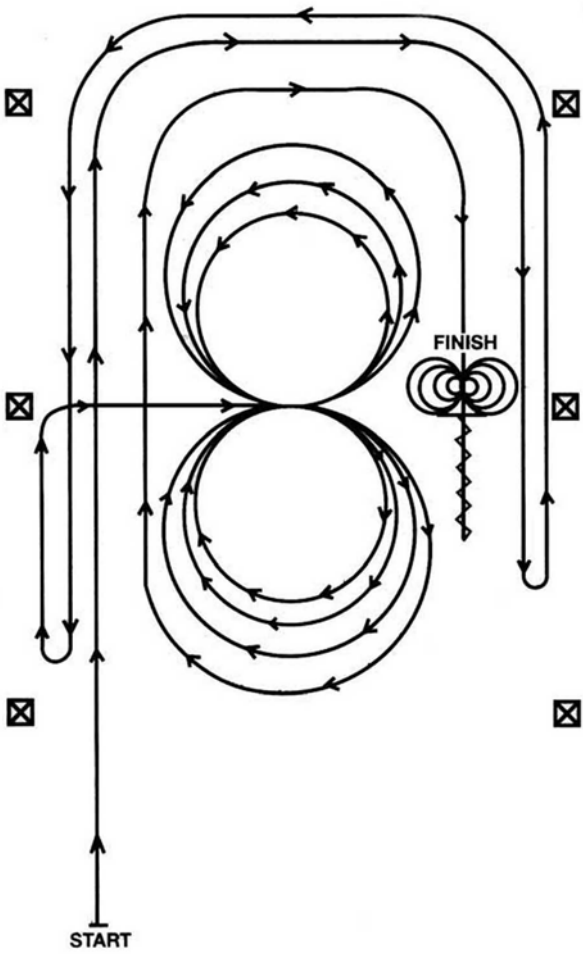
1. Run at speed to the far end of the arena past the end marker and do a left rollback – no hesitation.
2. Run to the opposite end of the arena past the end marker and do a right rollback – no hesitation.
3. Run past centre marker and do a sliding stop. Back up to centre of arena or at least three metres. Hesitate.
4. Complete four spins to the right. Hesitate.
5. Complete four and one-quarter spins to the left so that horse is facing left wall. Hesitate.
6. Beginning on the left lead, complete three circles to the left: first circle large and fast, second circle small and slow, third circle large and fast. Change leads at centre of the arena.
7. Complete three circles to the right: first circle large and fast, second circle small and slow, third circle large and fast. Change leads at centre of the arena.
8. Begin a large circle to the left but do not close the circle. Run straight up the right side of arena past centre marker and do a sliding stop at least six metres from wall. Hesitate to demonstrate completion of pattern.



## **PATTERN 2**

Horses may walk or jog to the centre of arena. Horses must walk or stop prior to starting pattern. Begin at the centre of the arena facing the left wall.

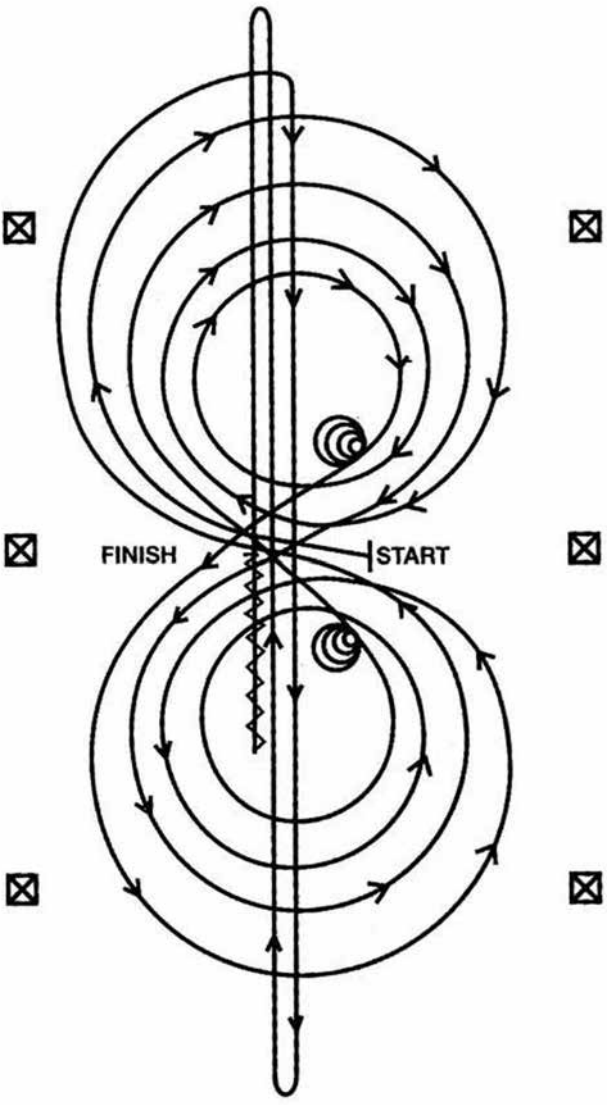
1. Beginning on the right lead, complete three circles to the right: the first circle small and slow, the next two circles large and fast. Change leads at the centre of the arena.
2. Complete three circles to the left: the first circle small and slow, the next two circles large and fast. Change leads at the centre of the arena.
3. Continue around previous circle to the right. At the top of the circle, run down the middle to the far end of the arena past the end marker and do a right rollback – no hesitation.
4. Run up the middle to the opposite end of the arena past the end marker and do a left rollback – no hesitation.
5. Run past the centre marker and do a sliding stop. Back up to the centre of the arena or at least 3 metres. Hesitate.
6. Complete four spins to the right. Hesitate.
7. Complete four spins to the left. Hesitate to demonstrate the completion of the pattern.





### **PATTERN 3**

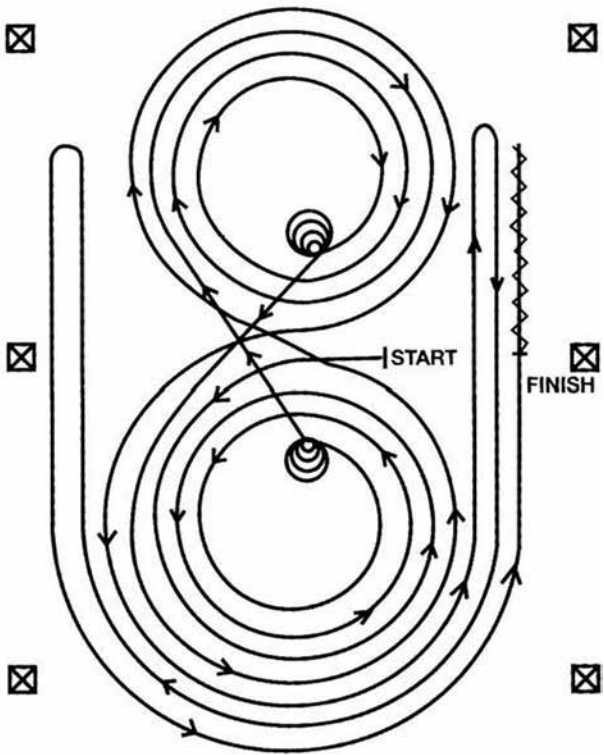
1. Beginning, lope straight up left side of the arena, circle the top end of arena, and staying at least 6 metres from the walls, run straight down the opposite or right side of the arena past centre marker and do a left rollback – no hesitation.
2. Continue straight up the right side of arena circle back around the top of arena, and staying at least 6 metres from the walls, run straight down the left side of arena past the centre marker and do a right roll back – no hesitation.
3. Continue up the left side of arena to centre marker. At the centre marker, the horse should be on the right lead. Guide the horse to the centre of the arena on the right lead and complete three circles to the right: the first two circles large and fast, the third circle small and slow. Change leads at the centre of the arena.
4. Complete three circles to the left: the first two circles large and fast, the third circle small and slow. Change leads in the centre of the arena.
5. Begin a large circle to the right but do not close this circle. Continue up the left side of the arena, circle the top of the arena, and staying at least 6 metres from the walls, run straight down the opposite or right side of the arena past the centre marker and do a sliding stop. Back up at least 6 metres. Hesitate.
6. Complete four spins to the right. Hesitate.
7. Complete four spins to the left. Hesitate to demonstrate the completion of the pattern.



## **PATTERN 4**

Horses may walk or jog to the centre of arena. Horses must walk or stop prior to starting pattern. Begin at the centre of the arena facing the left wall.

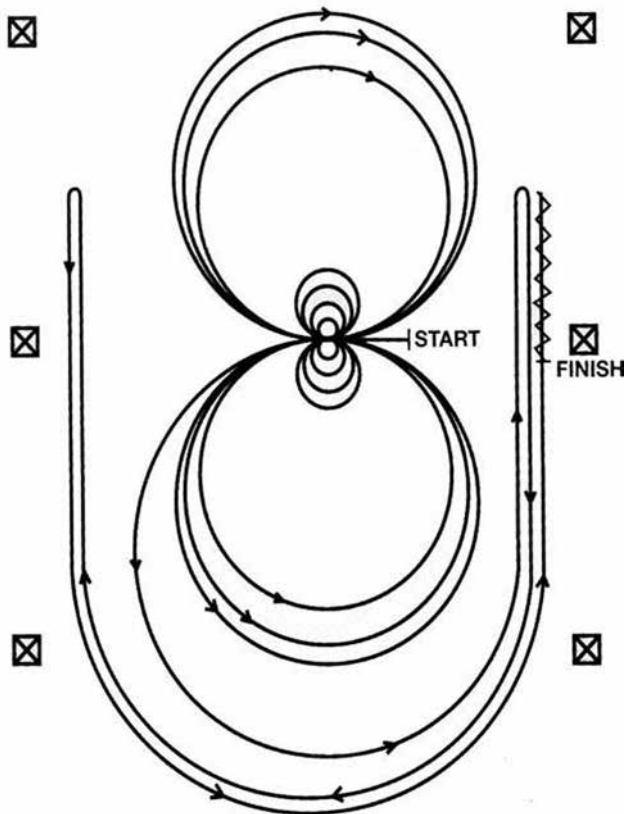
1. Beginning on the right lead, complete three circles to the right: the first two circles large and fast; the third circle small and slow. Stop at the centre of the arena. Hesitate.
2. Complete four spins to the right. Hesitate.
3. Beginning on the left lead, complete three circles to the left: the first two circles large and fast; the third circle small and slow. Stop at the centre of the arena. Hesitate.
4. Complete four spins to the left. Hesitate.
5. Beginning on the right lead, run a large fast circle to the right, change leads at the centre of the arena, run a large fast circle to the left, and change leads at the centre of the arena (figure 8).
6. Continue around previous circle to the right. At the top of the circle, run down the middle to the far end of the arena past the end marker and do a right roll-back – no hesitation.
7. Run up the middle to the opposite end of the arena past the end marker and do a left roll-back – no hesitation.
8. Run past the centre marker and do a sliding stop. Back up to the center of the arena at least three metres. Hesitate to demonstrate completion of pattern.



## PATTERN 5

Horses may walk or jog to the centre of arena. Horses must walk or stop prior to starting pattern. Begin at the centre of the arena facing the left wall.

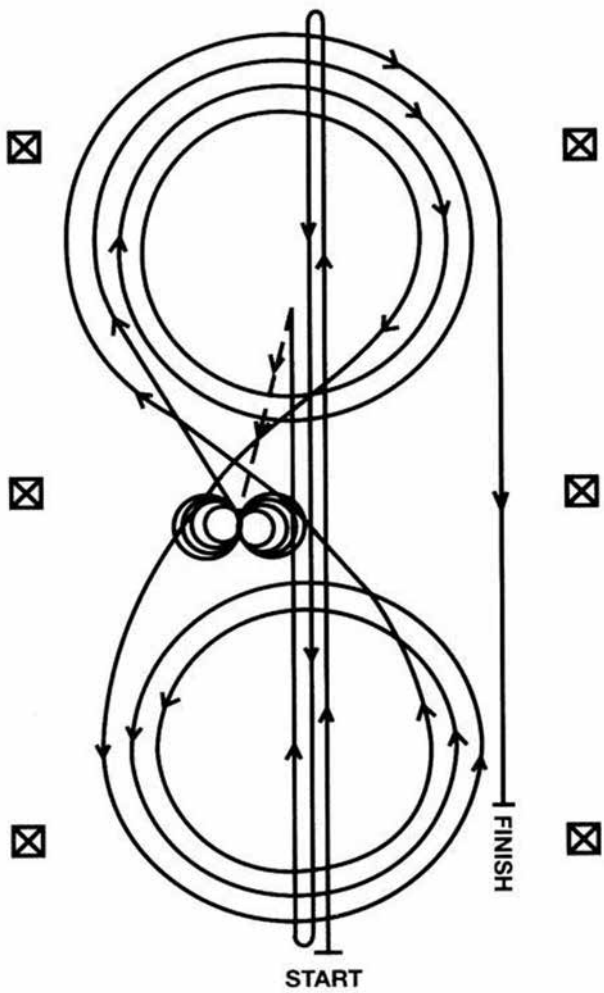
1. Beginning on the left lead, complete three circles to the left: the first two circles large and fast; the third circle small and slow. Stop at the centre of the arena. Hesitate.
2. Complete four spins to the left. Hesitate.
3. Beginning on the right lead, complete three circles to the right: the first two circles large and fast; the third circle small and slow. Stop at the centre of the arena. Hesitate.
4. Complete four spins to the right. Hesitate.
5. Beginning on the left lead, run a large fast circle to the left, change leads at the centre of the arena, run a large fast circle to the right, and change leads at the centre of the arena (figure 8).
6. Continue around previous circle to the left but do not close this circle. Run up right side of arena past center marker and do a right rollback at least six meters from wall – no hesitation.
7. Continue around previous circle but do not close this circle. Run up left side of arena past center marker and do a left rollback at least 6 meters from wall – no hesitation.
8. Continue back around previous circle but do not close this circle. Run up the right side of arena past center marker and do a sliding stop at least six meters from the wall. Back up at least three meters. Hesitate to demonstrate completion of pattern.



## **PATTERN 6**

Horses may walk or jog to the centre of arena. Horses must walk or stop prior to starting pattern. Begin at the centre of the arena facing the left wall.

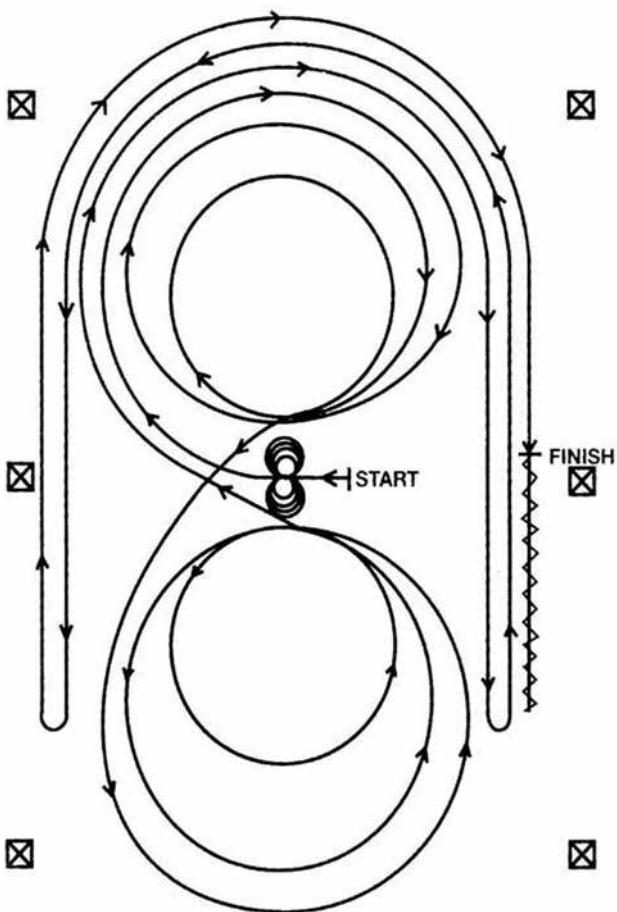
1. Complete four spins to the right. Hesitate.
2. Complete four spins to the left. Hesitate.
3. Beginning on left lead, complete three circles to the left: the first two circles large and fast, the third circle small and slow. Change leads at the center of the arena.
4. Complete three circles to the right: the first two circles large and fast, the third circle small and slow. Change leads at the center of the arena.
5. Begin a large circle to the left but do not close this circle. Run up the right side of the arena past the center marker and do a right rollback at least six meters from the wall – no hesitation.
6. Continue back around previous circle but do not close this circle. Run up the left side of the arena past the center marker and do a left rollback at least three meters from the wall – no hesitation.
7. Continue back around the previous circle but do not close this circle. Run up the right side of the arena past the center marker and do a sliding stop at least three meters from the wall. Back up at least three meters. Hesitate to demonstrate the completion of the pattern.





## **PATTERN 7**

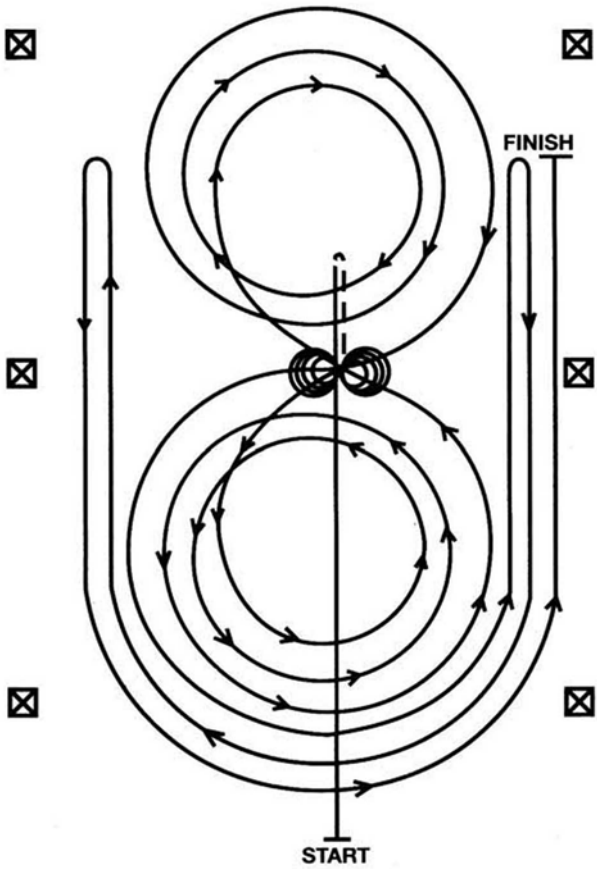
1. Run at speed to the far end of the arena past the end marker and do a left rollback - no hesitation.
2. Run to the opposite end of the arena past the end marker and do a right rollback – no hesitation.
3. Run past centre marker and do a sliding stop. Back up to centre of arena or at least three metres. Hesitate.
4. Complete four spins to the right. Hesitate.
5. Complete four and one-quarter spins to the left so that horse is facing left wall. Hesitate.
6. Beginning on the right lead, complete three circles to the right: the first two circles large and fast, the third circle small and slow. Change leads at the center of the arena.
7. Complete three circles to the left: the first two circles large and fast, the third circle small and slow. Change leads at the center of the arena.
8. Begin a large fast circle to the right but do not close this circle. Run straight down the right side of the arena past the center marker and do a sliding stop at least six meters from the wall. Hesitate to demonstrate the completion of the pattern.



## **PATTERN 8**

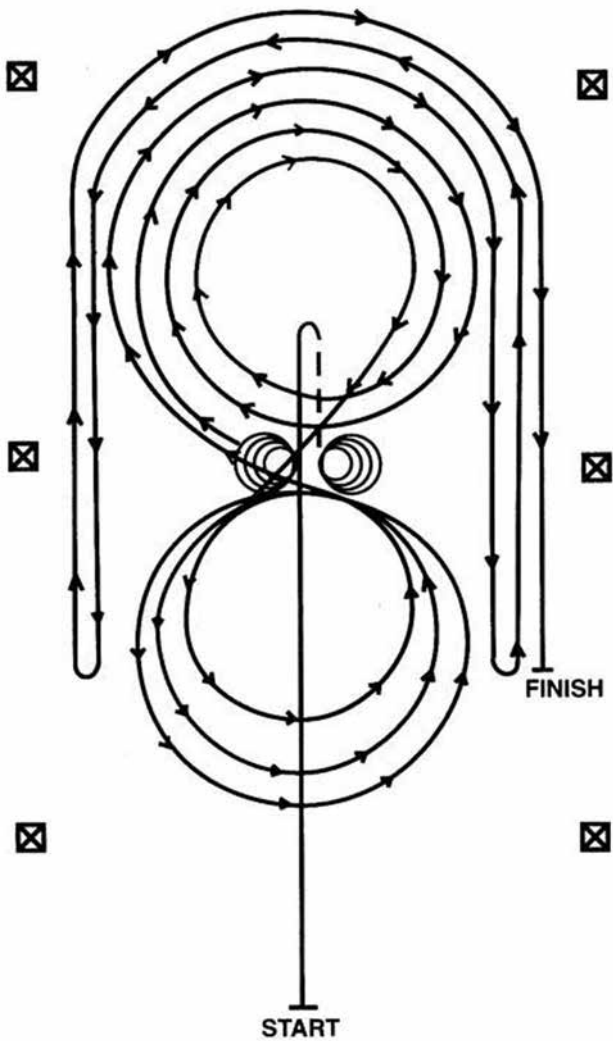
Horses may walk or jog to the centre of arena. Horses must walk or stop prior to starting pattern. Begin at the centre of the arena facing the left wall.

1. Complete four spins to the left. Hesitate.
2. Complete four spins to the right. Hesitate.
3. Beginning on right lead, complete three circles to the right: the first circle large and fast, second circle small and slow, third circle large and fast. Change leads at centre of arena.
4. Complete three circles to the left: first circle large and fast, second circle small and slow, third circle large and fast. Change leads at centre of arena.
5. Begin a large fast circle to the right but do not close this circle. Run straight down the right side of arena past centre marker and do a left rollback at least six metres from wall – no hesitation.
6. Continue back around previous circle but do not close this circle. Run down the left side of arena past centre marker and do a right rollback at least six metres from wall – no hesitation.
7. Continue back around previous circle but do not close this circle. Run down right side of arena past centre marker and do a sliding stop at least six metres from the wall. Back up at least three metres. Hesitate to demonstrate completion of pattern.



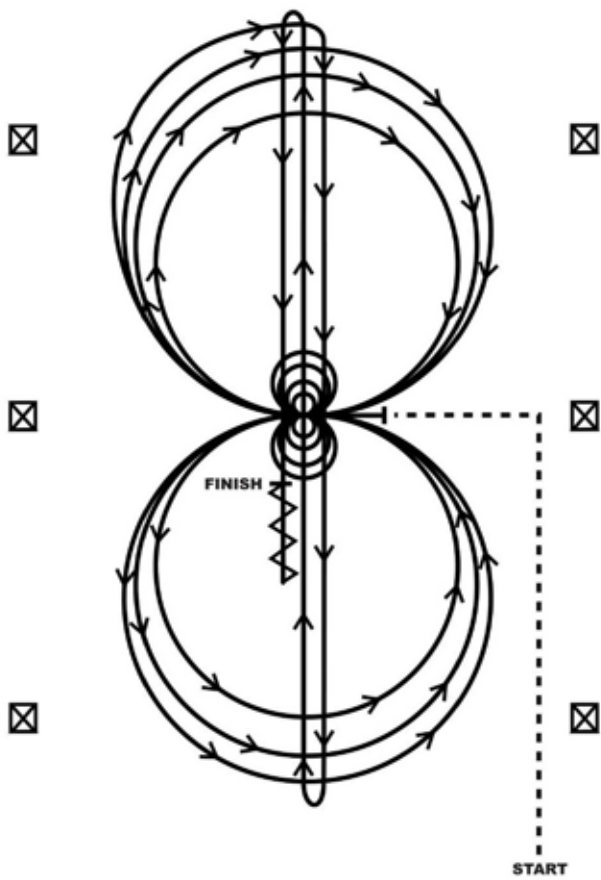
## PATTERN 9

1. Run past the center marker and do a sliding stop. Back up to the center of the arena or at least three meters. Hesitate.
2. Complete four spins to the right. Hesitate.
3. Complete four and one-quarter spins to the left so that horse is facing the left wall. Hesitate.
4. Beginning on the left lead, complete three circles to the left: the first circle small and slow, the next two circles large and fast. Change leads at the center of the arena.
5. Complete three circles to the right: the first circle small and slow, the next two circles large and fast. Change leads at the center of the arena.
6. Begin a large fast circle to the left but do not close this circle. Run up the right side of the arena past the center marker and do a right rollback at least six meters from the wall – no hesitation.
7. Continue back around the previous circle but do not close this circle. Run up the left side of the arena past the center marker and do a left rollback at least six meters from the wall – no hesitation.
8. Continue back around previous circle but do not close this circle. Run up right side of the arena past the center marker and do a sliding stop at least six meters from the wall. Hesitate to demonstrate completion of the pattern.



## **PATTERN 10**

1. Run past the center marker and do a sliding stop. Back up to the center of the arena or at least three meters. Hesitate.
2. Complete four spins to the right. Hesitate.
3. Complete four and one-quarter spins to the left so that horse is facing the left wall. Hesitate.
4. Beginning on the right lead, complete three circles to the right: first two circles large and fast, third circle small and slow. Change leads at the center of the arena.
5. Complete three circles to the left: first circle small and slow, next two circles are large and fast. Change leads at center of arena.
6. Begin a large circle to the right but do not close this circle. Run down the right side of arena past the center marker and do a left rollback at least 6 meters from the wall – no hesitation.
7. Continue back around the previous circle but do not close this circle. Run down left side of arena past center and do a right rollback at least 6 meters from the wall – no hesitation.
8. Continue back around previous circle but do not close this circle. Run down right side of arena past center marker and do a sliding stop at least 6 meters from the wall. Hesitate to demonstrate completion of pattern.

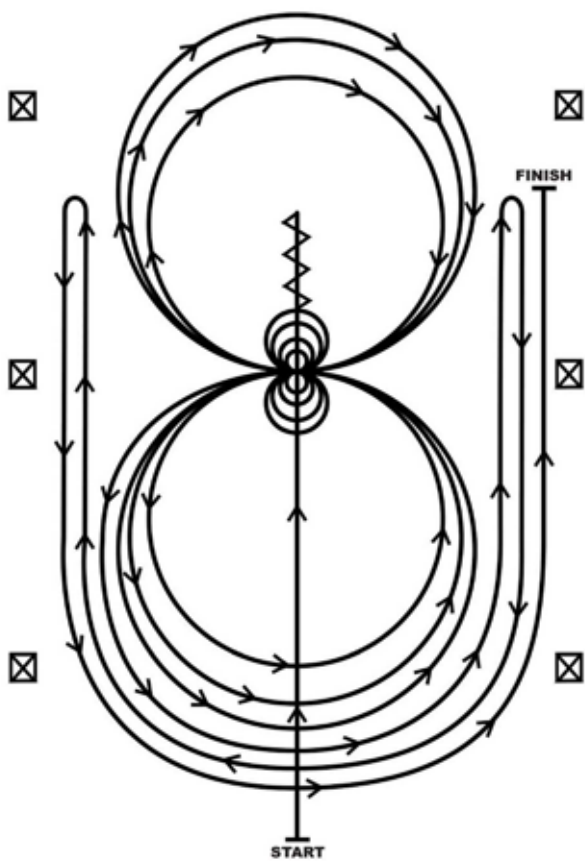




## **PATTERN 11**

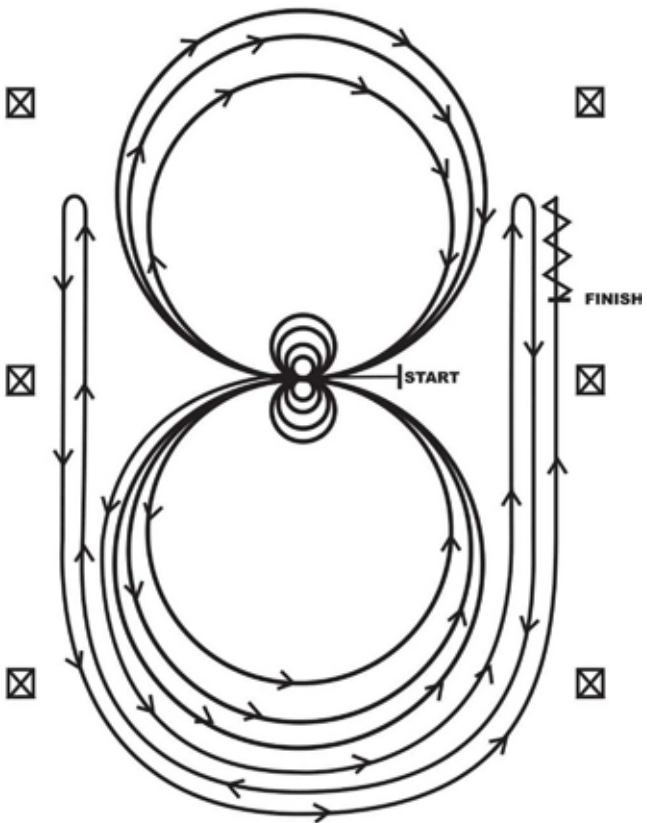
Horses must jog to the center of the arena. Horses must walk or stop prior to starting pattern. Begin at the center of the arena facing the left wall or fence.

1. Complete four spins to the left. Hesitate.
2. Complete four spins to the right. Hesitate.
3. Beginning on the right lead, complete three circles to the right; the first circle small and slow; the next two circles large and fast. Change leads at the center of the arena.
4. Complete three circles to the left; the first circle small and slow; the next two circles large and fast. Change leads at the center of the arena.
5. Begin a large circle to the right, but do not close this circle. Run down the center of the arena past the end marker and do a right rollback – no hesitation.
6. Run up the middle to the opposite end of the arena past the end marker and do a left roll back – no hesitation.
7. Run past the center marker and do a sliding stop. Back up to the center of the arena or at least three meters. Hesitate to demonstrate completion of the pattern.



## PATTERN 12

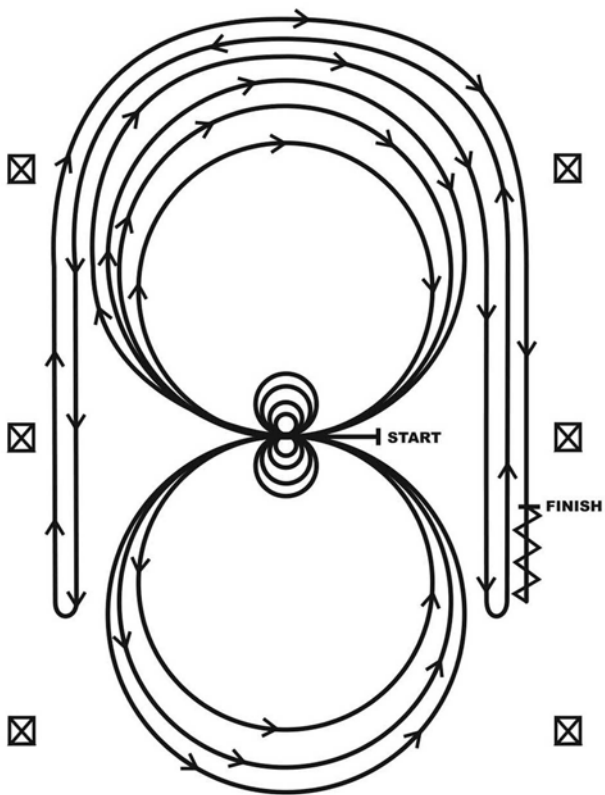
1. Run past the center marker and do a sliding stop. Back up to the center of the arena or at least three meters. Hesitate.
2. Complete four spins to the right. Hesitate.
3. Complete four and one-quarter spins to the left so that horse is facing the left wall. Hesitate.
4. Beginning on the left lead, compete three circles to the left: the first two circles large and fast; the third circle small and slow. Change leads at the centre of the arena.
5. Complete three circles to the right: the first two circles large and fast; the third circle small and slow. Change leads at the centre for the arena.
6. Begin a large circle to the left but do not close this circle. Run up the right side of arena past the center marker and do a right rollback at least 6 meters from the wall – no hesitation.
7. Continue back around the previous circle but do not close this circle. Run up left side of arena past center and do a left rollback at least 6 meters from the wall – no hesitation.
8. Continue back around previous circle but do not close this circle. Run up right side of arena past center marker and do a sliding stop at least 6 meters from the wall. Hesitate to demonstrate completion of pattern.



### **PATTERN 13**

Horses may walk or jog to the centre of arena. Horses must walk or stop prior to starting pattern. Begin at the centre of the arena facing the left wall.

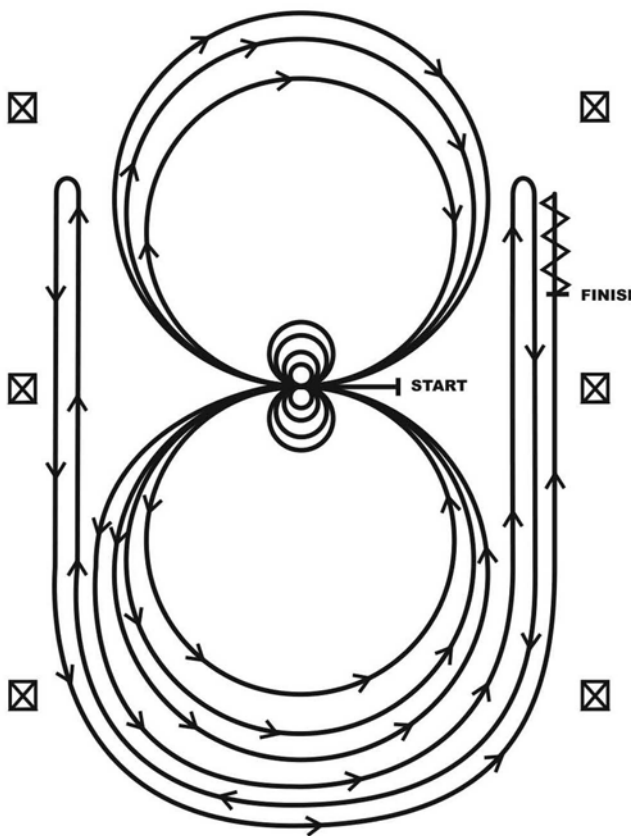
1. Beginning on the left lead, complete two circles to the left: the first circle large and fast; the second circle small and slow. Stop at the centre of the arena. Hesitate.
2. Complete four spins to the left. Hesitate.
3. Beginning on the right lead, complete two circles to the right: the first circle large and fast; the second circle small and slow. Stop at the centre of the arena. Hesitate.
4. Complete four spins to the right. Hesitate.
5. Beginning on the left lead, run a large fast circle to the left, change leads at the centre of the arena, run a large fast circle to the right, and change leads at the centre of the arena (figure 8).
6. Continue around previous circle to the left but do not close this circle. Run up the right side of the arena past the centre marker and do a right rollback at least 6 metres from the wall – no hesitation.
7. Continue around previous circle but do not close the circle. Run up the left side of the arena past the centre marker and do a left rollback at least 6 metres from the wall – no hesitation.
8. Continue back around previous circle but do not close this circle. Run up the right side of arena past centre marker and do a sliding stop at least 6 meters from the wall. Back up at least three meters. Hesitate to demonstrate completion of pattern.



## **PATTERN 14**

Horses may walk or jog to the centre of arena. Horses must walk or stop prior to starting pattern. Begin at the centre of the arena facing the left wall.

1. Complete four spins to the left. Hesitate.
2. Complete four spins to the right. Hesitate.
3. Beginning on right lead, complete three circles to the right: the first two circles large and fast, the third circle small and slow. Change leads at the center of the arena.
4. Complete three circles to the left: the first two circles large and fast, the third circle small and slow. Change leads at the center of the arena.
5. Begin a large circle to the right but do not close this circle. Run down the right side of the arena past the center marker and do a left rollback at least six meters from the wall – no hesitation.
6. Continue back around previous circle but do not close this circle. Run down the left side of the arena past the center marker and do a right rollback at least three meters from the wall – no hesitation.
7. Continue back around the previous circle but do not close this circle. Run down the right side of the arena past the center marker and do a sliding stop at least three meters from the wall. Back up at least three meters. Hesitate to demonstrate the completion of the pattern.

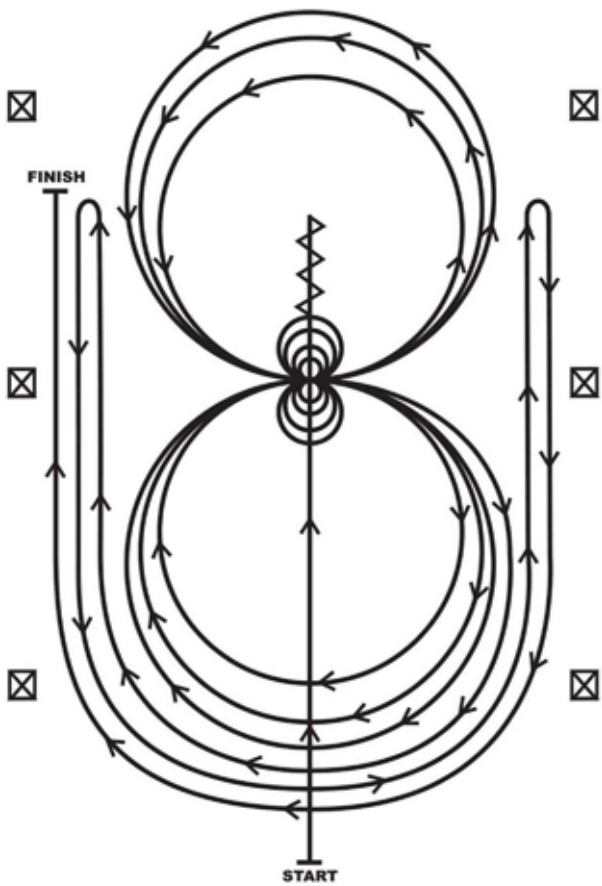




## **PATTERN 15**

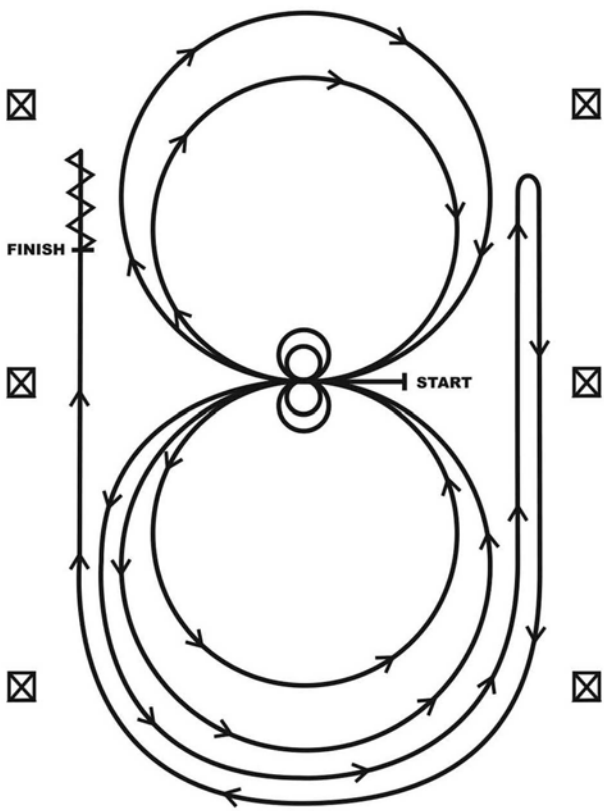
Horse may walk or jog to the centre of arena. Horses must walk or stop prior to starting pattern. Begin at the centre of the arena facing the left wall.

1. Complete four spins to the right. Hesitate.
2. Complete four spins to the left. Hesitate.
3. Beginning on left lead, complete three circles to the left: the first circle large and fast, second circle small and slow, third circle large and fast. Change leads at centre of arena.
4. Complete three circles to the right: first circle large and fast, second circle small and slow, third circle large and fast. Change leads at centre of arena.
5. Begin a large fast circle to the left but do not close this circle. Run straight up the right side of arena past centre marker and do a right rollback at least six metres from wall – no hesitation.
6. Continue back around previous circle but do not close this circle. Run up the left side of arena past centre marker and do a left rollback at least six metres from wall – no hesitation.
7. Continue back around previous circle but do not close this circle. Run up right side of arena past centre marker and do a sliding stop at least six metres from the wall. Back up at least three metres. Hesitate to demonstrate completion of pattern.



## PATTERN 16

1. Run past the center marker and do a sliding stop. Back up to the center of the arena or at least three meters. Hesitate.
2. Complete four spins to the left. Hesitate.
3. Complete four and one-quarter spins to the right so that horse is facing the right wall. Hesitate.
4. Beginning on the right lead, complete three circles to the right: first two circles large and fast, third circle small and slow. Change leads at the center of the arena.
5. Complete three circles to the left: first circle small and slow, next two circles are large and fast. Change leads at center of arena.
6. Begin a large circle to the right but do not close this circle. Run up the left side of arena past the center marker and do a left rollback at least 6 meters from the wall – no hesitation.
7. Continue back around the previous circle but do not close this circle. Run up right side of arena past center and do a right rollback at least 6 meters from the wall – no hesitation.
8. Continue back around previous circle but do not close this circle. Run up left side of arena past center marker and do a sliding stop at least 6 meters from the wall. Hesitate to demonstrate completion of pattern.

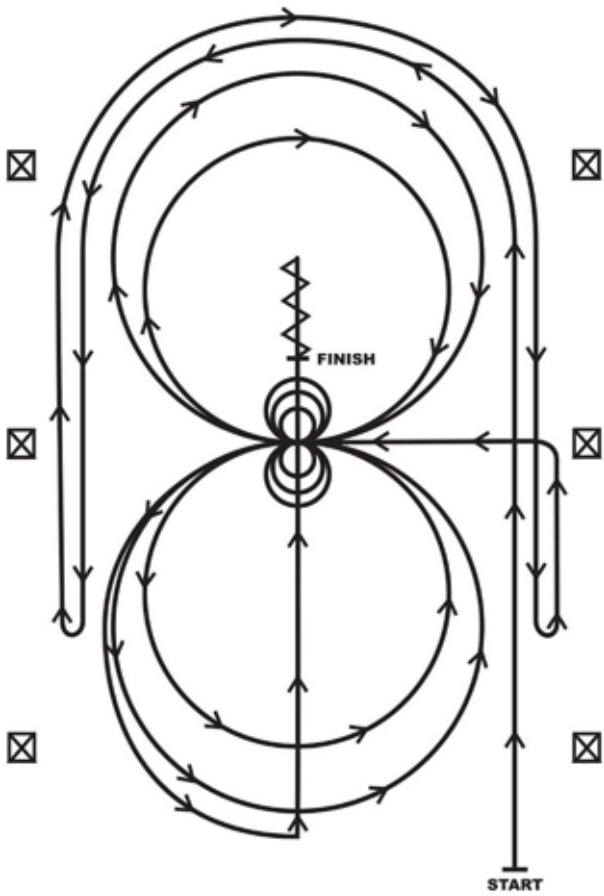


## **PATTERN A**

Can be used for Youth 10 and under, Short Stirrup and Para Reining.

Horse may walk or jog to the centre of arena. Horses must walk or stop prior to starting pattern. Begin at the centre of the arena facing the left wall.

1. Beginning on the left lead, complete two circles to the left. Stop at the centre of the arena. Hesitate.
2. Complete two spins to the left. Hesitate.
3. Beginning on right lead, complete two circles to the right. Stop at the centre of the arena. Hesitate.
4. Complete two spins to the right. Hesitate.
5. Beginning on the left lead, go around the end of the arena, run up the right side of the arena past the centre marker, stop and roll back right.
6. Continue around the end of the arena to run up the left side of the arena past the centre marker. Stop. Back up. Hesitate to demonstrate completion of the pattern.

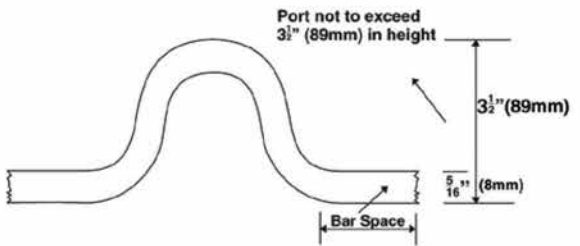


## **PATTERN B**

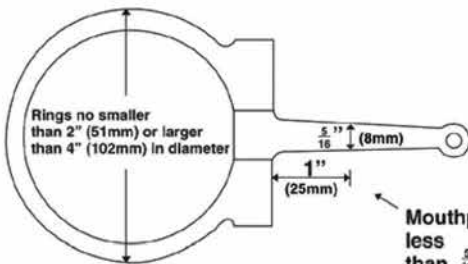
Can be used for Youth 10 and under, Short Stirrup and Para Reining.

1. Beginning, lope straight up the right side of the arena, circle the top of the arena, run straight down the opposite or left side of the arena past the centre marker and do a right rollback — no hesitation.
2. Continue straight up the left side of the arena, circle back around the top of the arena, run straight down the right side of the arena past the centre marker and do a left rollback — no hesitation.
3. Continue up the right side of the arena to the centre marker. At the centre marker the horse should be on the left lead. Complete two circles to the left, one large fast and one small slow. Stop at the centre. Hesitate.
4. Complete three spins to the left. Hesitate.
5. Complete two circles to the right, one large fast and one small slow. Stop at the centre. Hesitate.
6. Complete three spins to the right. Hesitate.
7. Begin a large circle to the left, do not close the circle. Continue up the centre of the arena past the centre marker and do a sliding stop. Back up at least three metres. Hesitate to demonstrate completion of the pattern.

# Figure #1 - Bit Measurements



Mouthpiece bar space no less than  $\frac{5}{16}$ " (8mm) in diameter, and must not be wire wrapped

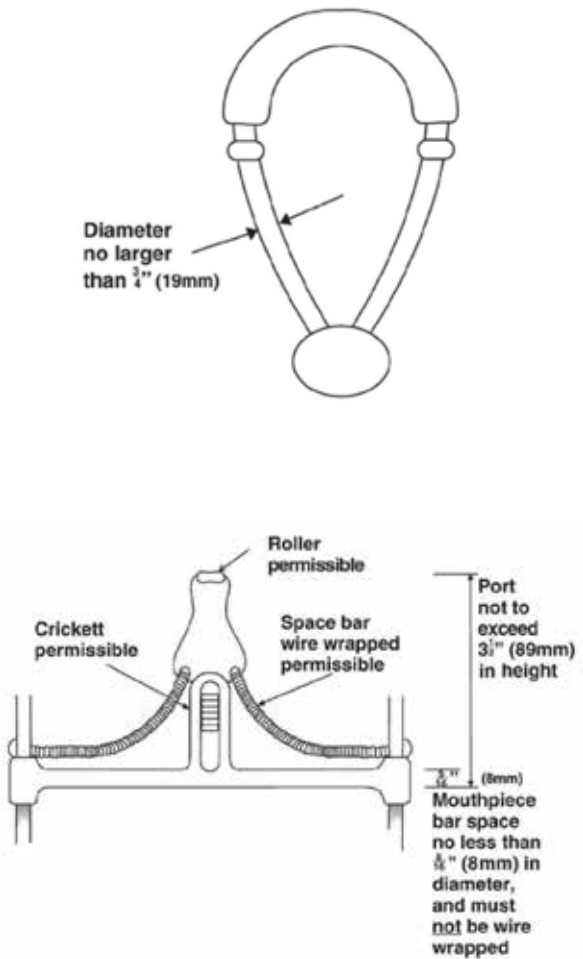


Mouthpiece no less than  $\frac{5}{16}$ " (8mm), measured 1" (25mm) from the cheek, constructed from smooth round material

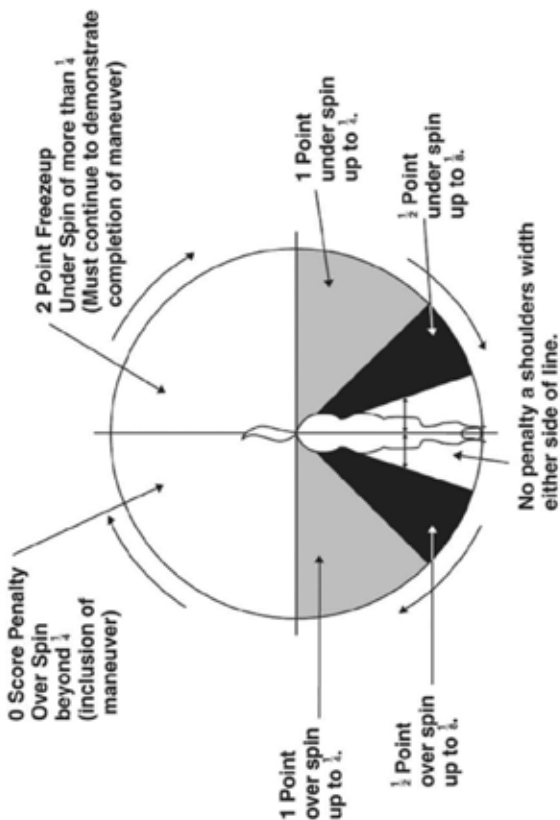




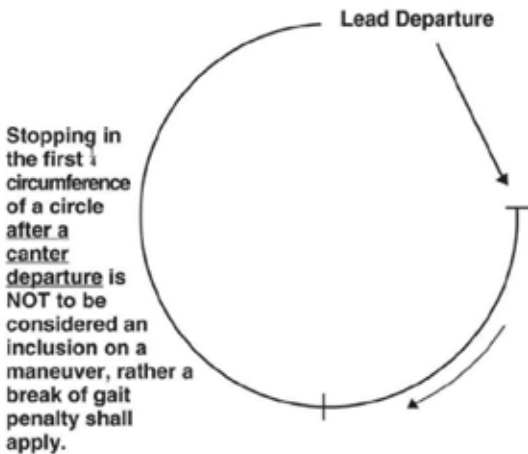
**Figure #2 - Bit Measurements**



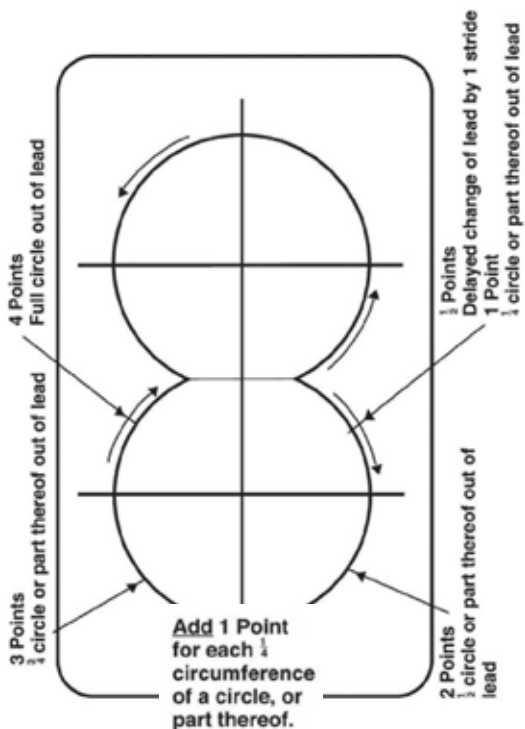
**Figure #3A - Over/Under Spin**



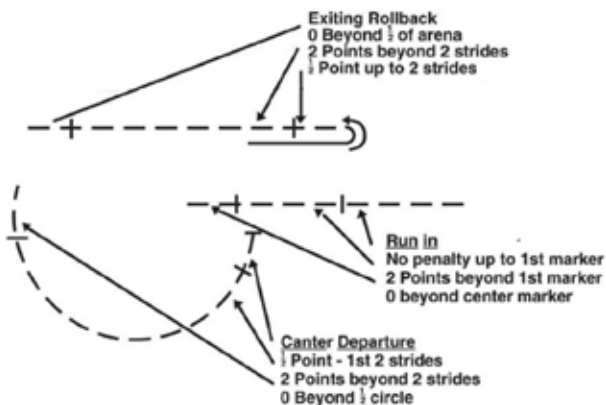
**Figure #3B - Lead Departure**



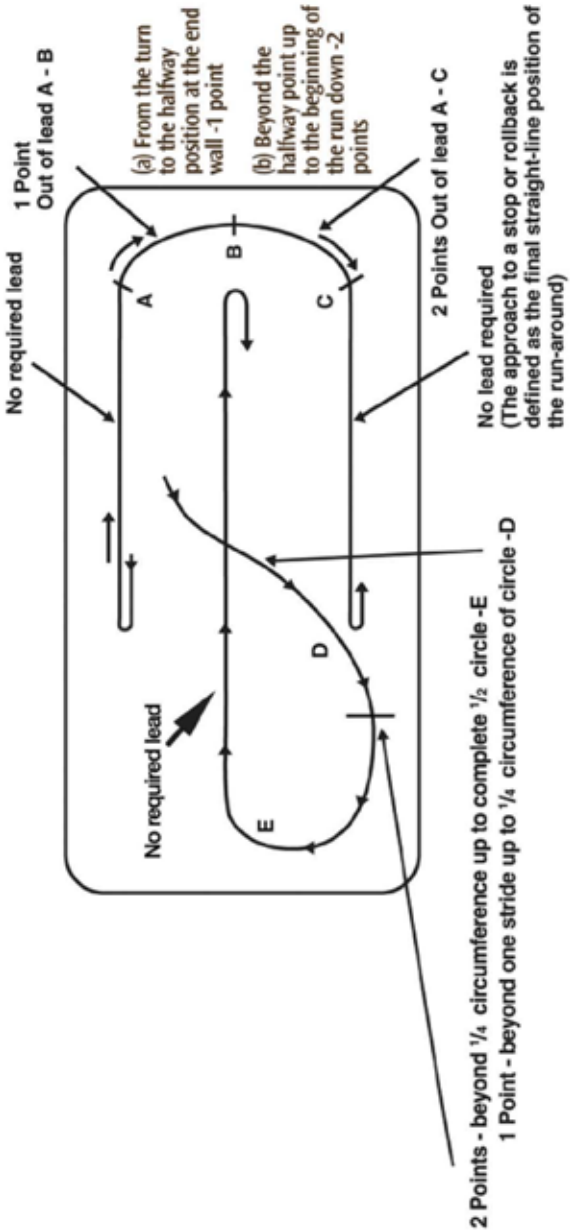
**Figure #4 - Out of Lead/Delayed Change**



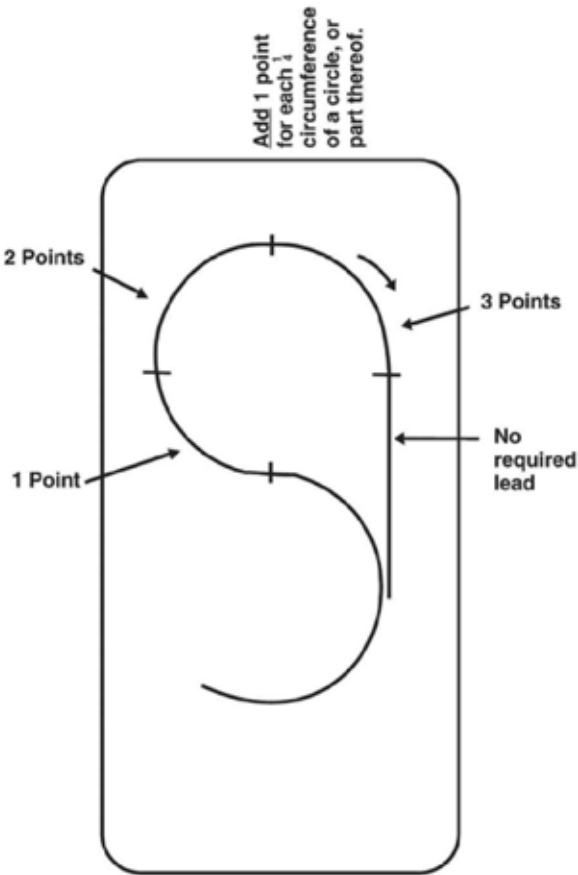
**Figure #5 - Jogging**



**Figure #6 - Out of Lead on Run-around**



**Figure #7 - Out of Lead on Partial Circle Leading to Run-down**



**Figure #8 - Sample Score Card**

Event		Date	Class	Patterns						
NRIHA JUDGES SCORE CARD				4						
MANEUVER SCORES: -1½ Extremely Poor, -1 Very Poor, -½ Poor, 0 Correct, +½ Good, +1 Very Good, +1½ Excellent										
MANEUVER DESCRIPTION	1	2	3	4	5	6	7	8	PENALTY TOTAL	SCORE
1 256	0	+½	+½	-½	0	+½	+½	+½	1½	70½
2 143	-½	0	-1	-½	0	+½	0	0	0	0
3 210	+½	+½	+1	+1	0	+½	+1	+½	1	75
4 178										
5 120										

**Figure #9 Sample Freestyle Score Card**

Event		Date	Class							
			Freestyle							
MANEUVER SCORES: -1½ Extremely Poor, -1 Very Poor, -½ Poor, 0 Correct, +½ Good, +1 Very Good, +1½ Excellent										
ARTISTIC SCORES: (+, 0, -) for Choreography, Originality, Musicality and Presentation & Balance.										
MANEUVER DESCRIPTION	1	2	3	4	5	6	7	8	ARTISTIC C.O.M.P.	SCORE
1 256	+½	0	+½	0	+½	+½	+½	+½	+	73
2 307	0	-½	0	0	0	-½	0	-½	2	64½



